



August 2008

Product Specification

Industrial Compact Flash Card

Industrial Rugged CompactFlash Card

– Hermit series –

Doc-No: 100-XCFCHA-02V3



*This document is for information use only and is **subject to change without prior notice**. APRO Co., Ltd. assumes no responsibility for any errors that may appear in this document, nor for incidental or consequential damages resulting from the furnishing, performance or use of this material. No part of this document may be reproduced, transmitted, transcribed, stored in a retrievable manner or translated into any language or computer language, in any form or by any means, electronic, mechanical, magnetic, optical, chemical, manual or otherwise, without the prior written consent of an officer of APRO Co., Ltd..*

All parts of the APRO documentation are protected by copyright law and all rights are reserved.

APRO and the APRO logo are registered trademarks of APRO Co., Ltd. CompactFlash is a U.S. registered trademark of SanDisk Corporation.

Product names mentioned herein are for identification purposes only and may be trademarks and/or registered trademarks of their respective companies.

© 2008 APRO Corporation. All rights reserved.

Revision History

<i>Rev.</i>	<i>Description</i>	<i>Update</i>
<i>1.0</i>	<i>Initial release and general changes</i>	<i>2006/07/31</i>
<i>2.0</i>	<i>- Rugged CF Card added. - New part number Decoder and part number list</i>	<i>2008/11/5</i>
<i>2.1</i>	<i>- Optional Conformal Coating Specification added</i>	<i>2008/11/27</i>
<i>2.2</i>	<i>- Specification of PIO mode and UDMA mode updated - 2.2 System Power Requirements updated</i>	<i>2008/12/09</i>

CONTENTS

1. INTRODUCTION	1
1.1. SCOPE.....	2
1.2. SYSTEM FEATURES	2
1.3. CFA 3.0 SPECIFICATION	2
1.4. ATA/ATAPI-6 STANDARD	2
1.5. TECHNOLOGY INDEPENDENCE - STATIC WEAR LEVELING	2
1.6. CONFORMAL COATING	3
2. PRODUCT SPECIFICATIONS	4
2.1. SYSTEM ENVIRONMENTAL SPECIFICATIONS	4
2.2. SYSTEM POWER REQUIREMENTS	4
2.3. SYSTEM PERFORMANCE	4
2.4. SYSTEM RELIABILITY.....	5
2.5. PHYSICAL SPECIFICATIONS	5
2.6. CAPACITY SPECIFICATIONS.....	6
3. INTERFACE DESCRIPTION.....	8
3.1. CF INTERFACE (COMPACTFLASH TYPE I).....	8
3.2. PIN ASSIGNMENTS	8
3.3. ELECTRICAL DESCRIPTION.....	9
4. ELECTRICAL SPECIFICATION.....	14
4.1. GENERAL DC CHARACTERISTICS	14
4.1.1. INTERFACE I/O AT 5.0V.....	14

4.1.2. INTERFACE I/O AT 3.3V	15
4.2. AC CHARACTERISTICS	16
4.2.1. ATTRIBUTE MEMORY READ TIMING	16
4.2.2. CONFIGURATION REGISTER (ATTRIBUTE MEMORY) WRITE TIME	17
4.2.3. COMMON MEMORY READ TIMING	18
4.2.4. COMMON MEMORY WRITE TIMING	19
4.2.5. I/O READ TIMING	20
4.2.6. I/O WRITE TIMING	21
4.2.7. TRUE IDE PIO MODE READ/WRITE TIMING	22
4.2.8. TRUE IDE MULTIWORD DMA MODE READ/WRITE TIMING	24
4.2.9. ULTRA DMA SIGNAL IN EACH INTERFACE MODE	25
4.2.10. ULTRA DMA DATA BURST TIMING REQUIREMENT	26
4.2.11. ULTRA DMA DATA BURST TIMING DESCRIPTIONS	27
4.2.12. ULTRA DMA SENDER AND RECIPIENT IC TIMING REQUIREMENTS	28
4.2.13. ULTRA DMA AC SIGNAL REQUIREMENTS	28
4.2.14. ULTRA DMA DATA-IN BURST INITIATION TIMING	29
4.2.15. SUSTAINED ULTRA DMA DATA-IN BURST TIMING	30
4.2.16. ULTRA DMA DATA-IN BURST HOST PAUSE TIMING	30
4.2.17. ULTRA DMA DATA-IN BURST DEVICE TERMINATION TIMING	31
4.2.18. ULTRA DMA DATA-IN BURST HOST TERMINATION TIMING	32
4.2.19. ULTRA DMA DATA-OUT BURST HOST INITIATION TIMING	33
4.2.20. SUSTAINED ULTRA DMA DATA-OUT BURST HOST INITIATION TIMING	34
4.2.21. ULTRA DMA DATA-OUT BURST DEVICE PAUSE TIMING	35
4.2.22. ULTRA DMA DATA-OUT BURST DEVICE TERMINATION TIMING	36
4.2.23. ULTRA DMA DATA-OUT BURST HOST TERMINATION TIMING	37

5.	INTERFACE REGISTER DEFINITION.....	38
5.1.	DEVICE ADDRESS.....	38
5.2.	I/O REGISTER DESCRIPTIONS.....	38
6.	SOFTWARE SPECIFICATION.....	40
6.1.	ATA COMMAND SET.....	40
6.2.	ATA COMMAND DESCRIPTION.....	42
6.3.	ID TABLE INFORMATION	49
APPENDIX A.	ORDERING INFORMATION.....	51
APPENDIX B.	LIMITED WARRANTY.....	53
APPENDIX C.	AFTER SERVICE.....	54

1. Introduction

APRO Industrial CompactFlash (CF) Card – Hermit series designed to follow ATAPI-6 (ATA-100) standard. The main used Flash memories are Samsung SLC-NAND Type Flash memory chips. The available card capacities are 128MB, 256MB, 512MB, 1GB, 2GB, 4GB, 8GB and 16GB. The operating temperature grade is optional for commercial level 0°C ~ 70°C and wide temperature level -40°C ~ +85°C. The APRO Industrial CompactFlash (CF) Cards- Hermit series are designed electrically complies with the conventional IDE hard Card and support True IDE Mode. The data transfer modes supports PIO mode 0, 1, 2, 3, 4, 5 and 6 or MDMA- 0,1,2,3, and 4 or UDMA- 0, 1, 2, 3, 4 and 5. The fastest reading speed is up to 40 MB/sec and writing speed is up to 20 MB/sec. In order to sustain various harsh and tough operating environments, APRO especially delivers the CompactFlash frame kit in rugged metal as well as provides the optional treatment of conformal coating upon customers' request.

The APRO Industrial CF products provide a high level interface to the host computer. This interface allows a host computer to issue commands to the CompactFlash (CF) Card to read or write blocks of memory. Each sector is protected by a powerful 4 bits Error Correcting Code (ECC). APRO Industrial CompactFlash (CF) Card's Hermit series intelligent controller manages interface protocols, data storage and retrieval as well as ECC, defect handling and diagnostics, power management and clock control.

Figure 1 shows a block diagram of the used high tech Industrial CompactFlash (CF) Card controller.

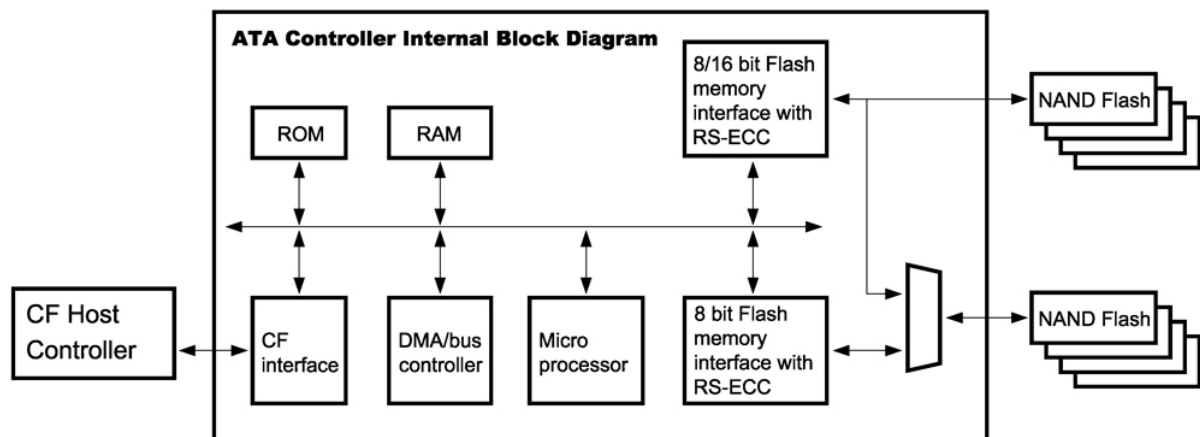

Figure 1: CompactFlash Card Hermit series Controller Block Diagram

1.1. Scope

This document describes the features and specifications and installation guide of APRO's Industrial CF Cards – Hermit series. In the appendix, there provides order information, warranty policy, RMA/DOA procedure for the most convenient reference.

1.2. System Features

- Optional Rugged metal CompactFlash casing to sustain the harshest environments
- Non-volatile memory and no moving parts
- SLC-NAND type flash technology
- Card capacity from 128MB to 16GB
- ATA inter face and support PC Card Memory mode, PC Card I/O mode and True IDE mode
- Data transfer supports PIO-4 and UDMA-4 (Default setting)
- Performance up to 40 MB/sec
- Automatic 4 bits error correction (ECC) and retry capabilities
- +5 V $\pm 10\%$ or +3.3 V $\pm 5\%$ operation
- MTBF 3,000,000 hours.
- Shock : 1,500G , compliance to MIL-STD-810F
- Vibration : 15G, compliance to MIL-STD-810F
- Support various rugged and harsh environments
- Very high performance, very low power consumption
- Low weight, Noiseless
- Conformal coating upon special request

1.3. CFA 3.0 Specification

APRO Industrial CF Cards – Hermit series is fully compatible with the CFA 3.0 specification.

1.4. ATA/ATAPI-6 Standard

APRO Industrial CF Cards – Hermit series is compliant to ATA/ATAPI-6 and below version.

1.5. Technology Independence - Static Wear Leveling

In order to gain the best management for flash memory, APRO Industrial CF Cards – Hermit series supports **Static Wear Leveling technology** to manage the Flash system. The life of flash memory is limited; the management is to increase the life of the flash product.

A static wear-leveling algorithm evenly distributes data over an entire Flash cell array and searches for the least used physical blocks. The identified low cycled sectors are used to write the data to those locations. If blocks are empty, the write occurs normally. If blocks contain static data, it moves that data to a more heavily used location before it moves the newly written data. The static wear leveling maximizes effective endurance Flash array compared to no wear leveling or dynamic wear leveling.

1.6. Conformal coating

Conformal coating is a protective, dielectric coating designed to conform to the surface of an assembled printed circuit board. Commonly used conformal coatings include silicone, acrylic, urethane and epoxy. APRO applies only silicone on APRO storage products upon request especially by customers. The type of silicone coating features good thermal shock resistance due to flexibility. It is also easy to apply and repair.

Conformal coating offers protection of circuitry from moisture, fungus, dust and corrosion caused by extreme environments. It also prevents damage from those Flash storage products handling during construction, installation and use, and reduces mechanical stress on components and protects from thermal shock. The greatest advantage of conformal coating is to allow greater component density due to increased dielectric strength between conductors.

APRO uses MIL-I-46058C silicon conformal coating.

2. Product Specifications

For all the following specifications, values are defined at ambient temperature and nominal supply voltage unless otherwise stated.

2.1. System Environmental Specifications

Table 1: Environmental Specification

		Commercial Grade	Industrial Grade
APRO Industrial CF Hermit series		SPCFxxxx-HACSC Series	WPCFxxxx-HAISI Series
Temperature	Operating:	0°C ~ +70°C	-40°C ~ +85°C
	Non-operating:	-55°C ~ +95°C	-55°C ~ +95°C
Humidity	Operating & Non-operating:	10% ~ 95% non-condensing	
Vibration	Operating & Non-operating:	15G peak-to-peak maximum	
Shock	Operating & Non-operating:	1,500G maximum	
Altitude	Operating & Non-operating:	70,000 feet	

2.2. System Power Requirements

Table 2: Power Requirement

	Commercial Grade	Industrial Grade
APRO Industrial CF -Hermit series	SPCFxxxx-HACSC Series	WPCFxxxx-HAISI Series
DC Input Voltage (VCC)	5V±10% or 3.3V±10%	
Reading mode	1 channel 78ma(Max.) / 2 channel 124ma(Max) UDMA-4 mode	
Writing mode	1 channel 67ma(Max.) / 2 channel 121ma(Max) UDMA-4 mode	
Sleeping mode	1 channel 1.2ma(Max.) / 2 channel 1.8ma(Max) UDMA-4 mode	

2.3. System Performance

Table 3: System Performances

Data Transfer Mode supporting			- PIO mode : 0, 1, 2, 3, 4, 5 and 6 (PIO – 4 defaulted) - DMA SW Mode: Not supported - DMA MW Mode:0,1,2, 3 and 4 - UDMA Mode: 0,1,2,3, 4 and 5 (UDMA-4 defaulted)							
Data Transfer Rate To/From Host			16.6Mbytes/sec burst under PIO Mode 4 as defaulted 66.6Mbytes/sec burst under UDMA-4 Mode as defaulted							
Average Access Time			0.6 ms(estimated)							
Maximum Performance	Capacity		128MB	256MB	512MB	1GB	2GB	4GB	8GB	16GB
	Sequential Read (MB/s)	PIO- 4	4.6	4.7	4.6	4.6	4.7	4.7	4.6	4.7
		UDMA -4	18.5	33.7	21.1	21.1	39.6	39.6	39.6	39.0
	Sequential Write(MB/s)	PIO- 4	4.2	4.4	4.0	4.4	4.6	4.6	4.0	4.5
UDMA -4		18.6	16.7	19.7	19.4	19.9	19.9	19.4	18.7	
The number of Channel			Single	Dual	Single	Single	Dual	Dual	Dual	Dual

Note:

- (1). All values quoted are typically at 25°C and nominal supply voltage.
- (2). Testing of the Industrial CompactFlash (CF) Card maximum performance was performed under the following platform:
 - Computer with AMD 3.0GHz processor
 - Windows XP Professional operating system

2.4. System Reliability

Table 4: System Reliability

MTBF	3,000,000 hours
Data Reliability	<1 non-recoverable error in 10^{14} bits read <1 erroneous correction in 10^{20} bits read
Wear-leveling Algorithms	Static wear-leveling algorithms
ECC Technology	4 bits Error Connection Code
Endurance	Greater than 2,000,000 cycles Logically contributed by static wear-leveling and advanced bad sector management
Data Retention	10 years

2.5. Physical Specifications

Refer to Table 5 and see Figure 3 for Industrial CF Hermit series physical specifications and dimensions.

Table 5: Physical Specifications

Industrial CompactFlash Card (Type I CompactFlash)	
Length:	36.40±0.15mm(1.433±0.006 in)
Width:	42.80±0.10mm(1.685±0.004 in)
Thickness:	3.3mm±0.10mm(.130±0.004 in) (Excluding Lip)
Weight:	12.0g(0.42oz) typical, 14.2 g(.0.5 oz)maximum

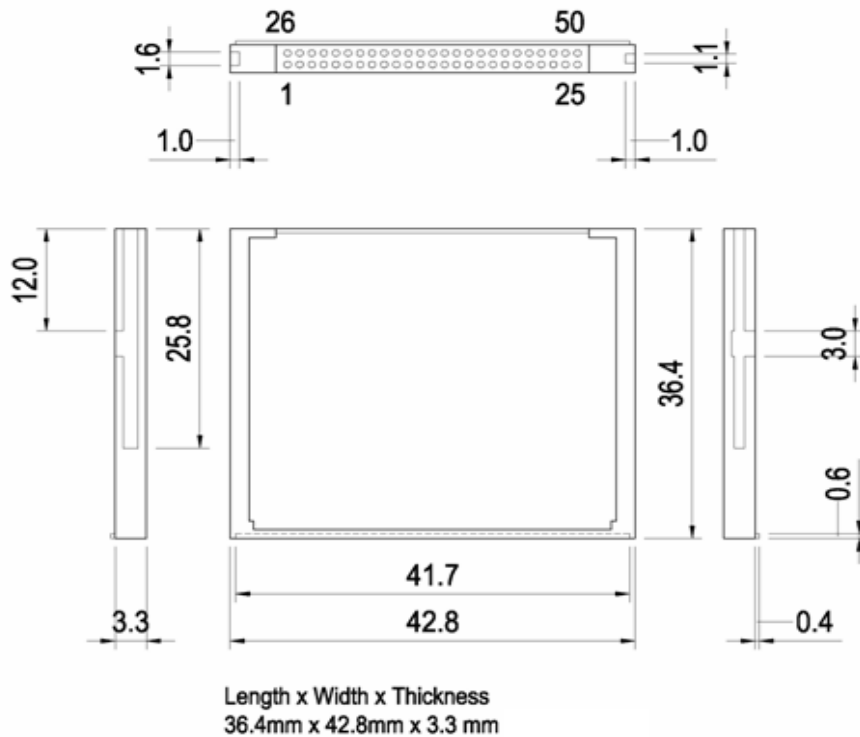

Figure 2: CompactFlash Card Dimension

2.6. Capacity Specifications

APRO Industrial CompactFlash (CF) Cards are built-in mainly Samsung NAND Type SLC Flash memory chips. The Table 6 shows the equipollent part number of applied Samsung Flash memory chips for each card.

Table 6: Card Configuration vs. Samsung NAND SLC part number

Card Capacity	Samsung SLC Flash Memory Part Number * Q'TY	
128MB	Commercial Grade:	K9F1G08U0A-PCB0(1Gb) or equipollent * 1
	Industrial Grade:	K9F1G08U0A-PIB0 (1Gb) or equipollent * 1
256MB	Commercial Grade:	K9F2G08U0A-PCB0 (2Gb) or equipollent * 1
		K9F1G08U0A-PCB0(1Gb) or equipollent * 2
	Industrial Grade:	K9F2G08U0A-PIB0 (2Gb) or equipollent * 1
		K9F1G08U0A-PIB0 (1Gb) or equipollent * 2
512MB	Commercial Grade:	K9F4G08U0M-PCB0 (4Gb) or equipollent * 1
		K9F2G08U0A-PCB0 (2Gb) or equipollent * 2
		K9F1G08U0A-PCB0(1Gb) or equipollent * 4
	Industrial Grade:	K9F4G08U0M-PIB0 (4Gb) or equipollent * 1
		K9F2G08U0A-PIB0 (2Gb) or equipollent * 2
		K9F1G08U0A-PIB0 (1Gb) or equipollent * 4
1GB	Commercial Grade:	K9K8G08U0M-PCB0 (8Gb) or equipollent * 1
		K9F4G08U0M-PCB0 (4Gb) or equipollent * 2
	Industrial Grade:	K9K8G08U0M-PIB0 (8Gb) or equipollent * 1
		K9F4G08U0M-PIB0 (4Gb) or equipollent * 2
2GB	Commercial Grade:	K9WAG08U1M-PCB0 (16Gb) or equipollent *1
		K9K8G08U0M-PCB0 (8Gb) or equipollent *2
	Industrial Grade:	K9WAG08U1M-PIB0 (16Gb) or equipollent *1
		K9K8G08U0M-PIB0 (8Gb) or equipollent *2
4GB	Commercial Grade:	K9WAG08U1M-PCB0 (16Gb) or equipollent *2
		K9K8G08U0M-PCB0 (8Gb) or equipollent *4
	Industrial Grade:	K9WAG08U1M-PIB0 (16Gb) or equipollent *2
		K9K8G08U0M-PIB0 (8Gb) or equipollent *4
8GB	Commercial Grade:	K9WAG08U1M-PCB0 (16Gb) or equipollent *4
	Industrial Grade:	K9WAG08U1M-PIB0 (16Gb) or equipollent *4
16GB	Commercial Grade:	K9WBG08U1M-PCB0 (32Gb) or equipollent *4
	Industrial Grade:	K9WBG08U1M-PIB0 (32Gb) or equipollent *4

The table 7 shows the specific capacity for the various models and the default number of heads, sectors/track and cylinders.

Table 7: Model Capacity

Unformatted Capacity	Default Cylinder	Default Head	Default Sector	Default CHS Capacity
128MB	500	16	32	256,000
256MB	1,000	16	32	512,000
512MB	1,015	16	63	1,023,120
1,024MB	2,031	16	63	2,047,248
2.04GB	4,063	16	63	4,095,504
4GB	8,146	16	63	8,211,168
8GB	16,000	16	63	16,128,000
16GB	32,235	16	63	32,492,880

3. Interface Description

3.1. CF interface (CompactFlash Type I)

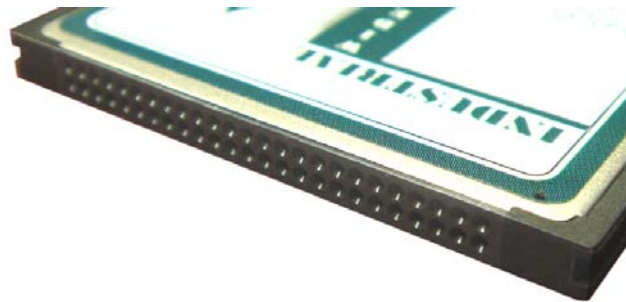

Figure 4: 50-pin CompactFlash Type I Connector

3.2. Pin Assignments

Signals whose source is the host is designated as inputs while signals that the Industrial CompactFlash (CF) Card sources are outputs. The pin assignments are listed in below table 8.

The signal/pin assignments are listed in below Table 8. Low active signals have a “-” prefix. Pin types are Input, Output or Input/Output.

Table 8: Pin Assignments and Pin Type

PC Card Memory Mode				PC Card I/O Mode				True IDE Mode ⁴			
Pin Num	Signal Name	Pin Type	In, Out Type	Pin Num	Signal Name	Pin Type	In, Out Type	Pin Num	Signal Name	Pin Type	In, Out Type
1	GND		Ground	1	GND		Ground	1	GND		Ground
2	D03	I/O	11Z,OZ3	2	D03	I/O	11Z,OZ3	2	D03	I/O	11Z,OZ3
3	D04	I/O	11Z,OZ3	3	D04	I/O	11Z,OZ3	3	D04	I/O	11Z,OZ3
4	D05	I/O	11Z,OZ3	4	D05	I/O	11Z,OZ3	4	D05	I/O	11Z,OZ3
5	D06	I/O	11Z,OZ3	5	D06	I/O	11Z,OZ3	5	D06	I/O	11Z,OZ3
6	D07	I/O	11Z,OZ3	6	D07	I/O	11Z,OZ3	6	D07	I/O	11Z,OZ3
7	-CE1	I	13U	7	-CE1	I	13U	7	-CS0	I	13Z
8	A10	I	11Z	8	A10	I	11Z	8	A10 ²	I	11Z
9	-OE	I	13U	9	-OE	I	13U	9	-ATA SEL	I	13U
10	A09	I	11Z	10	A09	I	11Z	10	A09 ²	I	11Z
11	A08	I	11Z	11	A08	I	11Z	11	A08 ²	I	11Z
12	A07	I	11Z	12	A07	I	11Z	12	A07 ²	I	11Z
13	VCC		Power	13	VCC		Power	13	VCC		Power
14	A06	I	11Z	14	A06	I	11Z	14	A06 ²	I	11Z
15	A05	I	11Z	15	A05	I	11Z	15	A05 ²	I	11Z
16	A04	I	11Z	16	A04	I	11Z	16	A04 ²	I	11Z
17	A03	I	11Z	17	A03	I	11Z	17	A03 ²	I	11Z
18	A02	I	11Z	18	A02	I	11Z	18	A02	I	11Z
19	A01	I	11Z	19	A01	I	11Z	19	A01	I	11Z
20	A00	I	11Z	20	A00	I	11Z	20	A00	I	11Z
21	D00	I/O	11Z,OZ3	21	D00	I/O	11Z,OZ3	21	D00	I/O	11Z,OZ3
22	D01	I/O	11Z,OZ3	22	D01	I/O	11Z,OZ3	22	D01	I/O	11Z,OZ3
23	D02	I/O	11Z,OZ3	23	D02	I/O	11Z,OZ3	23	D02	I/O	11Z,OZ3
24	WP	O	OT3	24	-IOIS16	O	OT3	24	-IOCS16	O	ON3
25	-CD2	O	Ground	25	-CD2	O	Ground	25	-CD2	O	Ground
26	-CD1	O	Ground	26	-CD1	O	Ground	26	-CD1	O	Ground

PC Card Memory Mode				PC Card I/O Mode				True IDE Mode ⁴			
Pin Num	Signal Name	Pin Type	In, Out Type	Pin Num	Signal Name	Pin Type	In, Out Type	Pin Num	Signal Name	Pin Type	In, Out Type
27	D11 ¹	I/O	11Z,OZ3	27	D11 ¹	I/O	11Z,OZ3	27	D11 ¹	I/O	11Z,OZ3
28	D12 ¹	I/O	11Z,OZ3	28	D12 ¹	I/O	11Z,OZ3	28	D12 ¹	I/O	11Z,OZ3
29	D13 ¹	I/O	11Z,OZ3	29	D13 ¹	I/O	11Z,OZ3	29	D13 ¹	I/O	11Z,OZ3
30	D14 ¹	I/O	11Z,OZ3	30	D14 ¹	I/O	11Z,OZ3	30	D14 ¹	I/O	11Z,OZ3
31	D15 ¹	I/O	11Z,OZ3	31	D15 ¹	I/O	11Z,OZ3	31	D15 ¹	I/O	11Z,OZ3
32	-CE2 ¹	I	13U	32	-CE2 ¹	I	13U	32	-CS1 ¹	I	13Z
33	-VS1	O	Ground	33	-VS1	O	Ground	33	-VS1	O	Ground
34	-IORD	I	13U	34	-IORD	I	13U	34	-IORD ⁷	I	13Z
									HSTROBE ⁸		
									-HDMARDY ⁹		
35	-IOWR	I	13U	35	-IOWR	I	13U	35	-IOWR ⁷	I	13Z
									STOP ^{8,9}		
36	-WE	I	13U	36	-WE	I	13U	36	-WE ³	I	13U
37	READY	O	OT1	37	-IREQ	O	OT1	37	INTRQ	O	OZ1
38	VCC		Power	38	VCC		Power	38	VCC		Power
39	-CSEL ⁵	I	12Z	39	-CSEL ⁵	I	12Z	39	-CSEL	I	12U
40	-VS2	O	OPEN	40	-VS2	O	OPEN	40	-VS2	O	OPEN
41	RESET	I	12Z	41	RESET	I	12Z	41	-RESET	I	12Z
42	-WAIT	O	OT1	42	-WAIT	O	OT1	42	IORDY ⁷	O	ON1
									-DDMARDY ⁸		
									DSTROBE ⁹		
43	-INPACK	O	OT1	43	-INPACK	O	OT1	43	DMARQ	O	OZ1
44	-REG	I	13U	44	-REG	I	13U	44	-DMACK ⁶	I	13U
45	BVD2	O	OT1	45	-SPKR	O	OT1	45	-DASP	I/O	11U,ON1
46	BVD1	O	OT1	46	-STSCHG	O	OT1	46	-PDIAG	I/O	11U,ON1
47	D08 ¹	I/O	11Z,OZ3	47	D08 ¹	I/O	11Z,OZ3	47	D08 ¹	I/O	11Z,OZ3
48	D09 ¹	I/O	11Z,OZ3	48	D09 ¹	I/O	11Z,OZ3	48	D09 ¹	I/O	11Z,OZ3
49	D10 ¹	I/O	11Z,OZ3	49	D10 ¹	I/O	11Z,OZ3	49	D10 ¹	I/O	11Z,OZ3
50	GND		Ground	50	GND		Ground	50	GND		Ground

Note:

- 1) These signals are required only for 16 bit accesses and not required when installed in 8 bit systems. Devices should allow for 3-state signals not to consume current.
- 2) The signal should be grounded by the host.
- 3) The signal should be tied to VCC by the host.
- 4) The mode is optional for CF+ Cards, but required for CompactFlash Cards.
- 5) The -CSEL signal is ignored by the card in PC Card modes. However, because it is not pulled up on the card in these modes, it should not be left floating by the host in PC Card modes. In these modes, the pin should be connected by the host to PC Card A25 or grounded by the host.
- 6) If DMA operations are not used, the signal should be held high or tied to VCC by the host. For proper operation in older hosts: while DMA operations are not active, the card shall ignore this signal, including a floating condition
- 7) Signal usage in True IDE Mode except when Ultra DMA mode protocol is active.
- 8) Signal usage in True IDE Mode when Ultra DMA mode protocol DMA Write is active.
- 9) Signal usage in True IDE Mode when Ultra DMA mode protocol DMA Read is active.

3.3. Electrical Description

The APRO Industrial CompactFlash Card -Hermit series is optimized for operation with hosts, which support the PCMCIA/ I/O interface standard conforming to the PC Card ATA specification. However, the CompactFlash Card may also be configured to operate in systems that support only the memory interface standard. The configuration of the CompactFlash Card will be controlled using the standard PCMCIA configuration registers starting at address 200h in the Attribute Memory space of the CompactFlash Card.

Table 9: describes the I/O signals. Signals whose source is the host are designated as inputs while signals that the CompactFlash Card sources are outputs. The CompactFlash Card logic levels conform to those specified in the *PCMCIA Release 2.1 Specification*. See Section 3.3 for definitions of Input and Output type.

Table 9: Signal Description

Signal Name	Dir	Pin	Description
A10 – A0 (PC Card Memory Mode)	I	8,10,11,12,14 ,15,16,17,18, 19,20	These address lines along with the –REG signal are used to select the following : The I/O port address registers within the CompactFlash Card or CF+ Card, the memory mapped port address registers within the CompactFlash Card or CF+ Card, a byte in the card's information structure and its configuration control and status registers.
A10 – A0 (PC Card I/O Mode)			This signal is the same as the PC Card Memory Mode signal.
A2 – A0 (True IDE Mode)	I	18,19,20	In True IDE Mode, only A[2:0] are used to select the one of eight registers in the Task File, the remaining address lines should be grounded by the host.
BVD1 (PC Card Memory Mode) -STSCHG (PC Card I/O Mode) Status Changed -PDIAG (True IDE Mode)	I/O	46	This signal is asserted high, as BVD1 is not supported. This signal is asserted low to alert the host to changes in the READY and Write Protect states, while the I/O interface is configured. It use is controlled by the Card Config and Status Register. In the True IDE Mode, this input / output is the Pass Diagnostic signal in the Master / Slave handshake protocol.
BVD2 (PC Card Memory Mode) -SPKR (PC Card I/O Mode) -DASP (True IDE Mode)	I/O	45	This signal is asserted high, as BVD2 is not supported. This line is the Binary Audio output from the card. If the Card does not support the Binary Audio function, this line should be held negated. In the True IDE Mode, this input/output is the Disk Active/Slave Present signal in the Master/Slave handshake protocol.
-CD1, -CD2 (PC Card Memory Mode) -CD1, -CD2 (PC Card I/O Mode) -CD1, -CD2 (True IDE Mode)	O	26,25	These Card Detect pins are connected to ground on the CompactFlash Card or CF+ Card. They are used by the host to determine that the CompactFlash Card or CF+ Card is fully inserted into its socket. This signal is the same for all modes. This signal is the same for all modes.
-CE1, -CE2 (PC Card Memory Mode) Card Enable -CE1, -CE2 (PC Card I/O Mode) Card Enable -CS0, -CS1 (True IDE Mode)	I	7,32	These input signals are used both to select the card and to indicate to the card whether a byte or a word operation is being performed. –CE2 always accesses the odd byte of the word. –CE1 accesses the even byte or the Odd byte of the word depending on A0 and –CE2. A multiplexing scheme based on A0, -CE1, -CE2 allows 8 bit hosts to access all data on D0-D7. See Table 35, Table 37, Table40, Table41 and Table 42. This signal is the same as the PC Card Memory Mode signal. In the True IDE Mode, -CS0 is the chip select for the task file registers while –CS1 is used to select the Alternate Status Register and the Device Control Register. While –DMACK is asserted, -CS0 and –CS1 shall be held negated and the width of the transfers shall be 16bits.
-CSEL	I	39	This signal is not used for this mode, but should be connected by the

Signal Name	Dir	Pin	Description
(PC Card Memory Mode) -CSEL (PC Card I/O Mode) -CSEL (True IDE Mode)			host to PC Card A25 or grounded by the host. This signal is not used for this mode, but should be connected by the host to PC Card A25 or grounded by the host. This internally pulled up signal is used to configure this device as a Master or a Slave when configured in the True IDE Mode. When the pin is open, this device is configured as a Slave.
D15 – D00 (PC Card Memory Mode) D15 – D00 (PC Card I/O Mode) D15 – D00 (True IDE Mode)	I/O	31,30,29,28,27,49,48,47,6,5,4,3,2,23,22,21	These lines carry the Data, Commands and Status information between the host and the controller. D00 is the LSB of the Even Byte of the Word. D08 is the LSB of the Odd Byte of the Word. This signal is the same as the PC Card Memory Mode signal. In True IDE Mode, all Task File operations occur in byte mode on the low order bus D[7:0] while all data transfers are 16 bit using D[15:0].
GND (PC Card Memory Mode) GND (PC Card I/O Mode) GND (True IDE Mode)	--	1,50	Ground This signal is the same for all modes. This signal is the same for all modes.
-INPACK (PC Card Memory Mode) -INPACK (PC Card I/O Mode) Input Acknowledge DMARQ (True IDE Mode)	O	43	This signal is not used in this mode. The Input Acknowledge signal is asserted by the CompactFlash Card or CF+ Card when the card is selected and responding to an I/O read cycle at the address that is on the address bus. This signal is used by the host to control the enable of any input data buffers between the CompactFlash Card or CF+ Card and the CPU. This signal is a DMA Request that is used for DMA data transfers between host and device. It shall be asserted by the device when it is ready to transfer data to or from the host. For Multiword DMA transfers, the direction of data transfer is controlled by –IORD and –IOWR. This signal is used in a handshake manner with –DMACK, i.e., the device shall wait until the host asserts –DMACK before negating DMARQ, and re-asserting DMARQ if there is more data to transfer. DMAARQ shall not be driven when the device is not selected. While a DMA operation is in progress, –CS0 and –CS1 shall be held negated and the width of the transfers shall be 16bits. If there is no hardware support for DMA mode in the host, this output signal is not used and should not be connected at the host. In this case, the BIOS must report that DMA mode is not supported by the host so that device will not attempt DMA mode. A host that does not support DMA mode and implements both PCMCIA and True-IDE modes of operation need not alter the PCMCIA mode connections while in True-IDE mode as long as this does not prevent proper operation in any mode.
-IORD (PC Card Memory Mode) -IORD (PC Card I/O Mode) -IORD (True IDE Mode –Except Ultra DMA Protocol Active) -HDMARDY	I	34	This signal is not used in this mode. This is an I/O Read strobe generated by the host. This signal gates I/O data onto the bus from the CompactFlash Card or CF+ Card when the card is configured to use the I/O interface. In True IDE Mode, while Ultra DMA mode is not active, this signal has the same function as in PC Card I/O Mode. In True IDE Mode when Ultra DMA mode DMA Read is active this

Signal Name	Dir	Pin	Description
<p>(True IDE Mode – In Ultra DMA Protocol DMA Read)</p> <p>HSTROBE</p> <p>(True IDE Mode – In Ultra DMA Protocol DMA Write)</p>			<p>signal is asserted by the host to indicate that the host is read to receive Ultra DMA data-in bursts. The host may negate –HDMARDY to pause an Ultra DMA transfer.</p> <p>In True IDE Mode when Ultra DMA mode DMA Write is active this signal is the data out strobe generated by the host. Both rising and falling edge of HSTROBE cause data to be latched by the device. The host may stop generating HSTROBE edges to pause an Ultra DMA data-out burst.</p>
<p>-IOWR</p> <p>(PC Card Memory Mode)</p> <p>-IOWR</p> <p>(PC Card I/O Mode)</p> <p>-IOWR</p> <p>(True IDE Mode – Except Ultra DMA Protocol Active)</p> <p>STOP</p> <p>(True IDE Mode – Ultra DMA Protocol Active)</p>	I	35	<p>This signal is not used in this mode.</p> <p>The I/O Write strobe pulse is used to clock I/O data on the Card Data bus into the CompactFlash Card or CF+ Card controller registers when the CompactFlash Card or CF+ Card is configured to use the I/O interface.</p> <p>The clocking shall occur on the negative to positive edge of the signal (trailing edge).</p> <p>In True IDE Mode, while Ultra DMA mode protocol is not active this signal has the same function as in PC Card I/O Mode.</p> <p>When Ultra DMA mode protocol is supported, this signal must be negated before entering Ultra DMA mode protocol.</p> <p>In True IDE Mode, while Ultra DMA mode protocol is active, the assertion of this signal causes the termination of the Ultra DMA burst.</p>
<p>-OE</p> <p>(PC Card Memory Mode)</p> <p>-OE</p> <p>(PC Card I/O Mode)</p> <p>-ATA SEL</p> <p>(True IDE Mode)</p>	I	9	<p>This is an Output Enable Strobe Generated by the host interface. It is used to read data from the CompactFlash Card or CF+ Card in Memory Mode and to read the CIS and configuration registers.</p> <p>In PC Card I/O Mode, this signal is used to read the CIS and configuration registers.</p> <p>To enable True IDE Mode this input should be grounded by the host.</p>
<p>READY</p> <p>(PC Card Memory Mode)</p> <p>-IREQ</p> <p>(PC Card I/O Mode)</p> <p>INTRQ</p> <p>(True IDE Mode)</p>	O	37	<p>In Memory Mode, this signal is set high when the CompactFlash Card or CF+ Card is ready to accept a new data transfer operation and is held low when the card is busy.</p> <p>At power up and at Reset, the READY signal is held low (bus) until the CompactFlash Card or CF+ Card has completed its power up or reset function. No access of any type should be made to the CompactFlash Card or CF+ Card during this time.</p> <p>Note, however, that when a card is powered up and used with RESET continuously disconnected or asserted, the Reset function of the RESET pin is disabled. Consequently, the continuous assertion of RESET from the application of power shall not cause the READY signal to remain continuously in the busy state.</p> <p>I/O Operation – After the CompactFlash Card or CF+ Card has been configured for I/O operation, this signal is used as –Interrupt Request. This line is strobed low to generate a pulse mode interrupt or held low for a level ode interrupt.</p> <p>In True IDE Mode signal is the active high Interrupt Request to the host.</p>
<p>-REG</p> <p>(PC Card Memory Mode) Attribute Memory Select</p> <p>-REG</p> <p>(PC Card I/O Mode)</p> <p>-DMACK</p> <p>(True IDE Mode)</p>	I	44	<p>This signal is used during Memory Cycles to distinguish between Common Memory and Register (Attribute) Memory accesses. High for Common Memory, Low for Attribute Memory.</p> <p>The signal shall also be active (low) during I/O Cycles when the I/O address is on the Bus.</p> <p>This is a DMA Acknowledge signal that is asserted by the host in response to DMARQ to initiate DMA transfers.</p>

Signal Name	Dir	Pin	Description
			<p>While DMA operations are not active, the card shall ignore the –DMACK signal, including a floating condition.</p> <p>If DMA operation is not supported by a True IDE Mode only host, this signal should be driven high or connected to VCC by the host.</p> <p>A host that does not support DMA mode and implements both PCMCIA and True-IDE modes of operation need not alter the PCMCIA mode connections while in True-IDE mode as long as this does not prevent proper operation all modes.</p>
RESET (PC Card Memory Mode) RESET (PC Card I/O Mode) -RESET (True IDE Mode)	I	41	<p>The CompactFlash Card or CF+ Card is Reset when the RESET pin is high with the following important exception:</p> <p>The host may leave the RESET pin open or keep it continually high from the application of power without causing a continuous Reset of the card. Under either of these conditions, the card shall emerge from power-up having completed an initial Reset.</p> <p>The CompactFlash Card or CF+ Card is also Reset when the Soft Reset bit in the Card Configuration Option Register is set.</p> <p>This signal is the same as the PC Card Memory Mode signal.</p> <p>In the True IDE Mode, this input pin is the active low hardware reset from the host.</p>
VCC (PC Card Memory Mode) VCC (PC Card I/O Mode) VCC (True IDE Mode)	--	13,38	<p>+5V, +3.3V power.</p> <p>This signal is the same for all modes.</p> <p>This signal is the same for all modes.</p>
-VS1 -VS2 (PC Card Memory Mode) -VS1 -VS2 (PC Card I/O Mode) -VS1 -VS2 (True IDE Mode)	O	33 40	<p>Voltage Sense Signals. –VS1 is grounded on the Card and sensed by the Host so that the CompactFlash Card or CF+ Card CIS can be read at 3.3 volts and –VS2 is reserved by PCMCIA for a secondary voltage and is not connected on the Card.</p> <p>This signal is the same for all modes.</p> <p>This signal is the same for all modes.</p>
-WAIT (PC Card Memory Mode) -WAIT (PC Card I/O Mode) IORDY (True IDE Mode –Except Ultra DMA Mode) -DDMARDY (True IDE Mode –Ultra DMA Write Mode) DSTROBE (True IDE Mode –Ultra DMA Read Mode)	O	42	<p>The –WAIT signal is driven low by the CompactFlash Card or CF+ Card to signal the host to delay completion of a memory or I/O cycle that is in progress.</p> <p>This signal is the same as the PC Card Memory Mode signal.</p> <p>In True IDE Mode, except in Ultra DMA modes, this output signal may be used as IORDY.</p> <p>In True IDE Mode, when Ultra DMA mode DMA Write is active, this signal is asserted by the host to indicate that the device is read to receive Ultra DMA data-in bursts. The device may negate –DDMARDY to pause an Ultra DMA transfer.</p> <p>In True IDE Mode, when Ultra DMA mode DMA Write is active, this signal is the data out strobe generated by the device. Both the rising and falling edge of DSTROBE cause data to be latched by the host. The device may stop generating DSTROBE edges to pause an Ultra DMA data-out burst.</p>
-WE (PC Card Memory Mode)	I	36	This is a signal driven by the host and used for strobing memory write data to the registers of the CompactFlash Card or CF+ Card

Signal Name	Dir	Pin	Description
-WE (PC Card I/O Mode) -WE (True IDE Mode)			when the card is configured in the memory interface mode. It is also used for writing the configuration registers. In PC Card I/O Mode, this signal is used for writing the configuration registers. In True IDE Mode, this input signal is not used and should be connected to VCC by the host.
WP (PC Card Memory Mode) Write Protect -IOIS16 (PC Card I/O Mode) -IOIS16 (True IDE Mode)	O	24	Memory Mode –The CompactFlash Card or CF+ Card does not have a write protect switch. This signal is held low after the completion of the reset initialization sequence. I/O Operation –When the CompactFlash Card or CF+ Card is configured for I/O Operation Pin 24 is used for the –I/O Selected is 16 Bit Port (-IOIS16) function. A Low signal indicates that a 16 bit or odd byte only operation can be performed at the addressed port. In True IDE Mode this output signal is asserted low when this device is expecting a word data transfer cycle.

4. Electrical Specification

Table 11, Table 12, and Table 13 defines all D.C. Characteristics for the Industrial CompactFlash (CF) Card . Unless otherwise stated, a condition is as below Table 10:

Table 10: Electrical Condition

Commercial Grade SPCFxxxH-ACSC Series	Industrial Grade WPCFxxxH-AISI- Series
V _{CC} = 5V ±10%	V _{CC} = 5V ±10%
V _{CC} = 3.3V ± 10%	V _{CC} = 3.3V ± 10%
T _a = 0°C to 70°C	T _a = -40°C to 85°C

4.1. General DC Characteristics

4.1.1. Interface I/O at 5.0V

Table 11: Interface I/O at 5.0V

Symbol	Parameter	Min.	Max.	Units	Remark
V _{CC}	Power Supply	4.5	5.5	V	
V _{OH}	Output Voltage High Level	V _{CC} -0.8		V	
V _{OL}	Output Voltage Low Level		0.8	V	
V _{IH}	Input Voltage High Level	2.92		V	Schmitt trigger ¹
V _{IL}	Input Voltage Low Level		1.70	V	Schmitt trigger ¹
T _{OPR-W}	Operating temperature for wide grade	-40	+85	°C	
T _{OPR-S}	Operating temperature for standard grade	0	+70	°C	
T _{STG}	Storage temperature	-40	125	°C	
R _{PU}	Pull up resistance ²	50	73	kOhm	
R _{PD}	Pull down resistance	50	97	kOhm	

4.1.2. Interface I/O at 3.3V

Table 12: Interface I/O at 3.3V

Symbol	Parameter	Min.	Max.	Units	Remark
V _{OH}	Power Supply	2.97	3.63	V	
V _{OL}	Output Voltage High Level	VCC-0.8		V	
V _{IH}	Output Voltage Low Level		0.8	V	
V _{IL}	Input Voltage High Level	2.05		V	Schmitt trigger ¹
V _{CC}	Input Voltage Low Level		1.25	V	Schmitt trigger ¹
T _{OPR-W}	Operating Temperature For Wide Grade	-40	+85	°C	
T _{OPR-S}	Operating Temperature For Standard Grade	0	+70	°C	
T _{STG}	Storage Temperature	-40	125	°C	
R _{PU}	Pull up resistance ²	52.7	141	kOhm	
R _{PD}	Pull down resistance	47.5	172	kOhm	

Notes:

- 1) Include CE1, CE2, HREG, HOE, HIOE, HWE, HIOW pins.
- 2) Include CE1, CE2, HREG, HOE, HIOE, HWE, HIOW, CSEL, PDIAG, DASP pins.

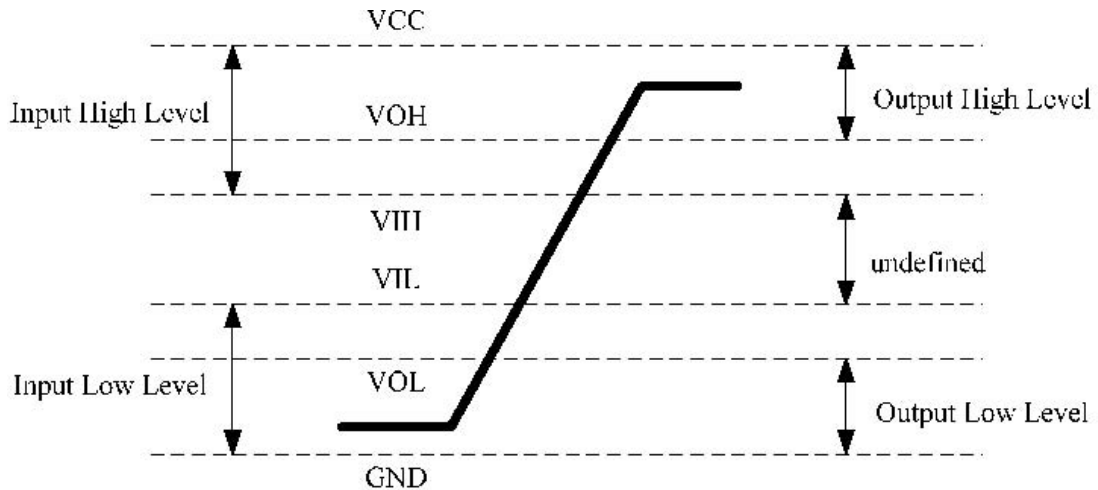

Figure 5: Interface I/O Voltage Diagram

4.2. AC Characteristics

4.2.1. Attribute Memory Read Timing

Table 13: Attribute Memory Read Timing

Speed Version	Symbol	300 ns	
Item		Min ns.	Max ns.
Read Cycle Time	tc (R)	300	
Address Access Time	ta (A)		300
Card Enable Access Time	ta (CE)		300
Output Enable Access Time	ta (OE)		150
Output Disable Time from CE	tdis (CE)		100
Output Disable Time from OE	tdis (OE)		100
Address Setup Time	tsu (A)	30	
Output Enable Time from CE	ten (CE)	5	
Output Enable Time from OE	ten (OE)	5	
Data Valid from Address Change	tv (A)	0	

Notes: All times are in nanoseconds. HD signifies data provided by the CompactFlash (CF) Card to the system. The CEx signal or both the HOE signal and the HWE signal shall be de-asserted between consecutive cycle operations.

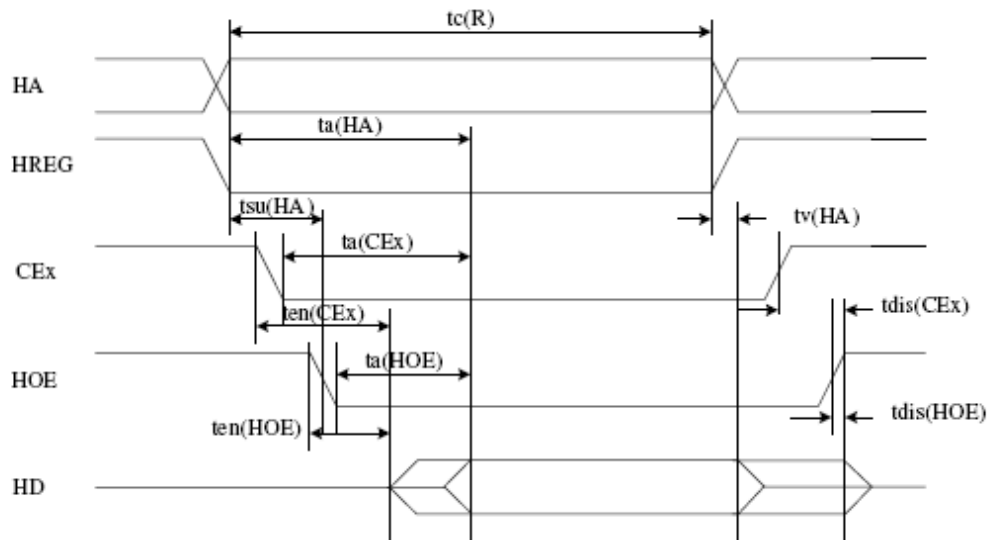

Figure6: Attribute Memory Read Timing Diagram

4.2.2. Configuration Register (Attribute Memory) Write Time

Table 14: Configuration Register (Attribute Memory) Write Time

Speed Version	Symbol	250 ns	
		Min ns.	Max ns.
Write Cycle Time	tc (W)	250	
Write Pulse Width	tw (WE)	150	
Address Setup Time	tsu (A)	30	
Write Recovery Time	trec (WE)	30	
Data Setup Time for HWE	tsu (D-WEH)	80	
Data Hold Time	th (D)	30	

Notes: All times are in nanoseconds. HD signifies data provided by the system to the CompactFlash (CF) Card.

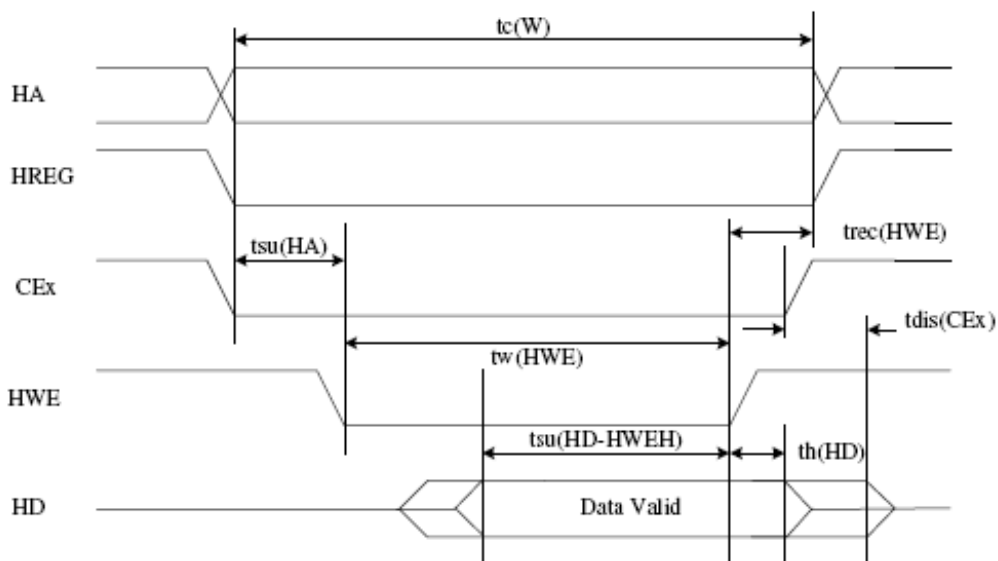

Figure 7: Configuration Register (Attribute Memory) Write Timing Diagram

4.2.3. Common Memory Read Timing

Table 15: Common Memory Read Timing

Cycle Time Mode		250 ns		120 ns		100 ns		80 ns	
Item	Symbol	Min ns.	Max ns.	Min ns.	Max ns.	Min ns.	Max ns.	Min ns.	Max ns.
Output Enable Access Time	ta (OE)		125		60		50		40
Output Disable Time from	t _{dis} (OE)		100		60		50		40
Address Setup Time	tsu (A)	30		15		10		10	
Address Hold Time	th (A)	20		15		15		10	
CE Setup before OE	tsu (CE)	0		0		0		0	
CE Hold following OE	th (CE)	20		15		15		10	
Wait Delay Falling from OE	t _v (WT-OE)		35		35		35		Na ¹
Data Setup for Wait Release	t _v (WT)		0		0		0		Na ¹
Wait Width Time ²	t _w (WT)		350		350		350		Na ¹

Notes:

- 1) IORDY is not supported in this mode
- 2) The Maximum load on IORDY is 1 LSTTL with 50pF (40pF below 120 nsec Cycle Time) total load. All times are in nanoseconds. HD signifies data provided by the CompactFlash (CF) Card to the system. The IORDY signal may be ignored if the HOE cycle to cycle time is greater than the Wait Width time. The Max Wait Width time can be determined from the Card Information Structure.

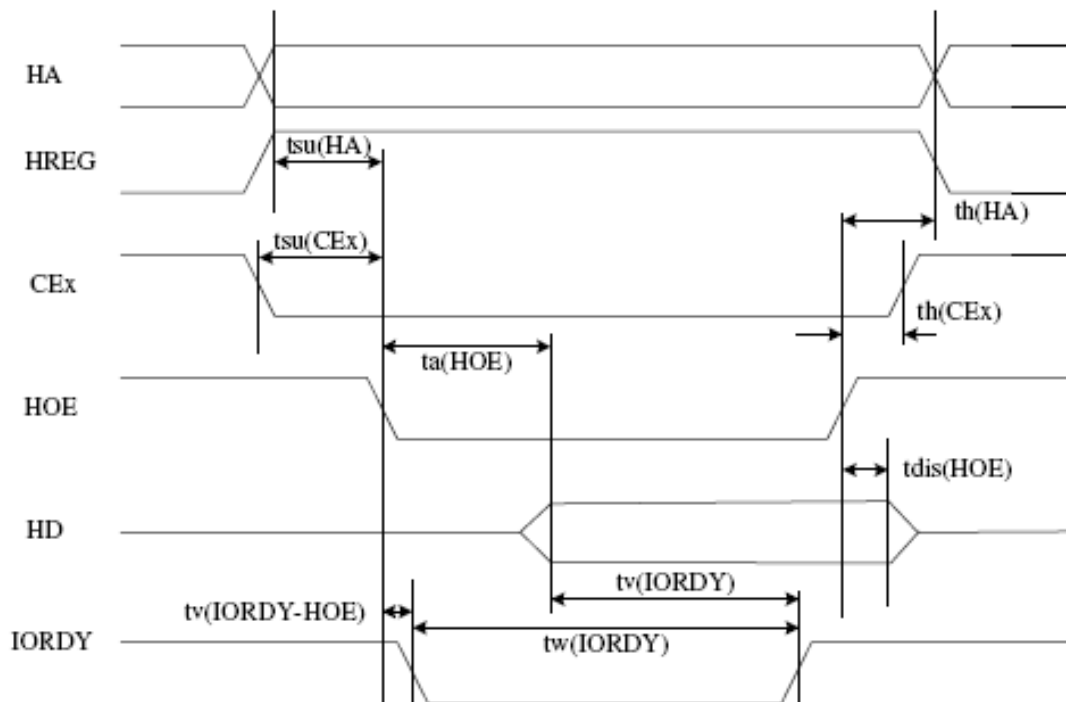

Figure 8: Common Memory Read Timing Diagram

4.2.4. Common Memory Write Timing

Table 16: Common Memory Write Timing

Cycle Time Mode		250 ns		120 ns		100 ns		80 ns	
Item	Symbol	Min ns.	Max ns.	Min ns.	Max ns.	Min ns.	Max ns.	Min ns.	Max ns.
Data Setup before WE	tsu (D-WEH)	80		50		40		30	
Data Hold following WE	th (D)	30		15		10		10	
WE Pulse Width	tw (WE)	150		70		60		55	
Address Setup Time	tsu (A)	30		15		10		10	
CE Setup before OE	tsu (CE)	0		0		0		0	
Write Recovery Time	trec (WE)	30		15		15		15	
Address Hold Time	th (A)	20		15		15		15	
CE Hold following OE	th (CE)	20		15		15		10	
Wait Delay Falling from OE	tv (WT-OE)		35		35		35		Na ¹
WE High from Wait Release	tv (WT)		0		0		0		Na ¹
Wait Width Time ²	tw (WT)		350		350		350		Na ¹

Notes:

- 1) *IORDY is not supported in this mode*
- 2) *The Maximum load on IORDY is 1 LSTTL with 50pF (40pF below 120 nsec Cycle Time) total load. All times are in nanoseconds. HD signifies data provided by the CompactFlash (CF) Card to the system. The IORDY signal may be ignored if the HOE cycle to cycle time is greater than the Wait Width time. The Max Wait Width time can be determined from the Card Information Structure.*

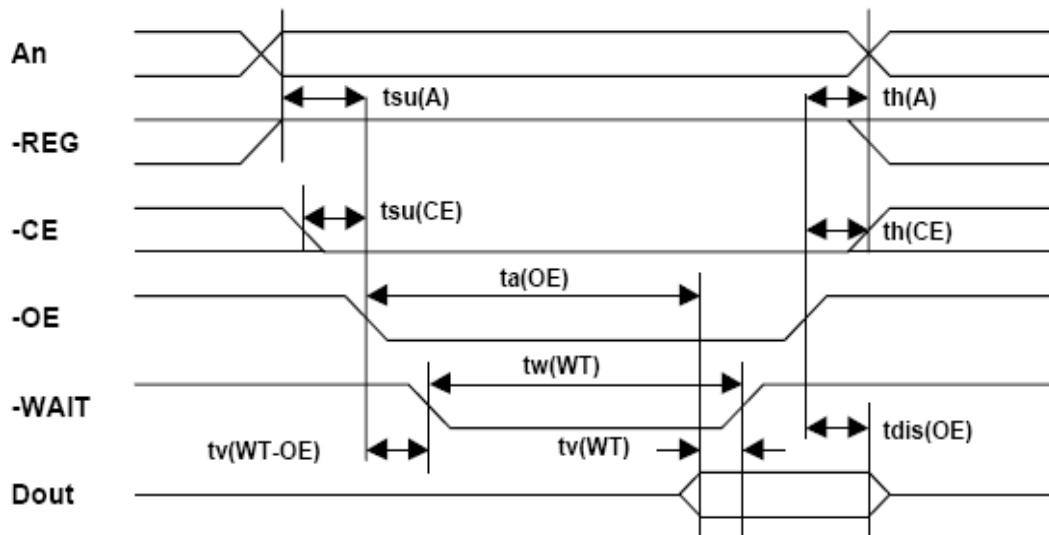

Figure 9: Common Memory Read Timing Diagram

4.2.5. I/O Read Timing

Table 17: I/O Read Timing

Cycle Time Mode		250 ns		120 ns		100 ns		80 ns	
Item	Symbol	Min ns.	Max ns.	Min ns.	Max ns.	Min ns.	Max ns.	Min ns.	Max ns.
Data Delay after IORD	td (IORD)		100		50		50		45
Data Hold following IORD	th (IORD)	0		5		5		5	
IORD Width Time	tw (IORD)	165		70		65		55	
Address Setup before IORD	tsuHA (IORD)	70		25		25		15	
Address Hold following IORD	thA (IORD)	20		10		10		10	
CE Setup before IORD	tsuCE (IORD)	5		5		5		5	
CE Hold following IORD	thCE (IORD)	20		10		10		10	
REG Setup before IORD	tsuREG(IORD)	5		5		5		5	
REG Hold following IORD	thREG (IORD)	0		0		0		0	
INPACK Delay Falling from IORD	tdFINPACK (IORD)	0	45	0	Na ¹	0	Na ¹	0	Na ¹
INPACK Delay Rising from IORD	tdrINPACK(IORD)		45		Na ¹		Na ¹		Na ¹
IOIS16 Delay Falling From Address	tdfIOIS16(ADR)		35		Na ¹		Na ¹		Na ¹
IOIS16 Delay Rising From Address	tdrIOIS16(ADR)		35		Na ¹		Na ¹		Na ¹
Wait Delay Falling From IORD	tdWT(IORD)		35		35		35		Na ²
Data Delay from Wait Rising	td(WT)		0		0		0		Na ²
Wait Width Time ²	tw(WT)		350		350		350		Na ²

Notes: 1) -IOIS16 and -INPACK are not supported in this mode.

2) -WAIT is not supported in this mode.

3) Maximum load on -WAIT, -INPACK and -IOIS16 is 1 LSTTL with 50 pF (40pF below 120nsec Cycle Time) total load. All times are in nanoseconds. Minimum time from -WAIT high to -IORD high is 0 nsec, but minimum -IORD width shall still be met. Dout signifies data provided by the CompactFlash Storage Card or CF+ Card to the system. Wait Width time meets PCMCIA specification of 12μs but is intentionally less in this spec.

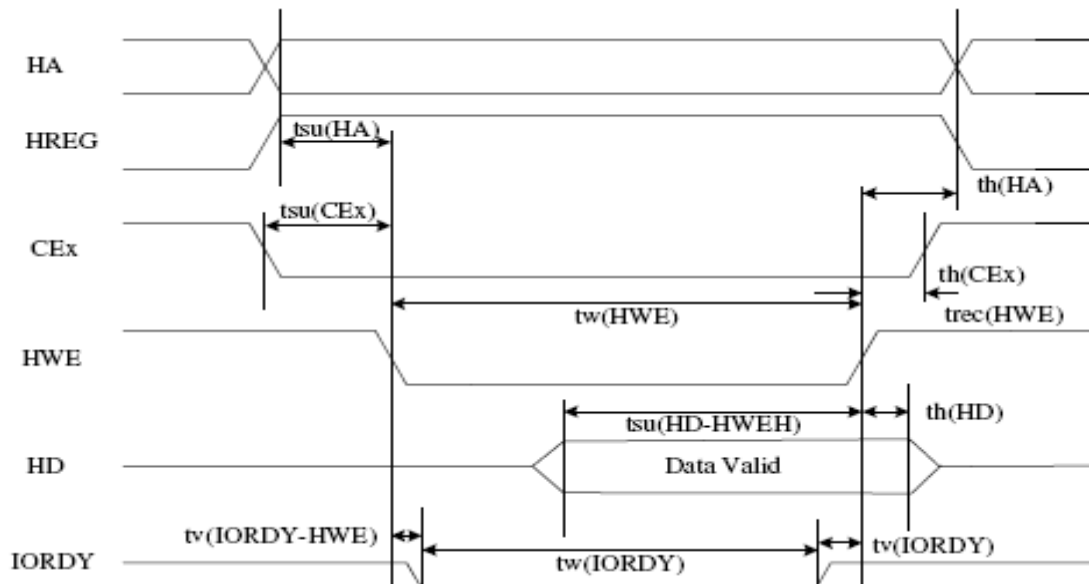

Figure10: I/O Read Timing Diagram

4.2.6. I/O Write Timing

Table 18: I/O Write Timing

Cycle Time Mode		250 ns		120 ns		100 ns		80 ns	
Item	Symbol	Min ns.	Max ns.	Min ns.	Max ns.	Min ns.	Max ns.	Min ns.	Max ns.
Data Setup before IOWR	tsu (IOWR)	60		20		20		15	
Data Hold following IOWR	th (IOWR)	30		10		5		5	
IOWR Width Time	tw (IOWR)	165		70		65		55	
Address Setup before IOWR	tsuA (IOWR)	70		25		25		15	
Address Hold following IOWR	thA (IOWR)	20		20		10		10	
CE Setup before IOWR	tsuCE (IOWR)	5		5		5		5	
CE Hold following IOWR	thCE (IOWR)	20		20		10		10	
REG Setup before IOWR	tsuREG(IOWR)	5		5		5		5	
REG Hold following IOWR	thREG (IOWR)	0		0		0		0	
IOIS16 Delay Falling from Address	tdfIOIS16(ADR)		35		Na ¹		Na ¹		Na ¹
IOIS16 Delay Rising from Address	tdrIOIS16(ADR)		35		Na ¹		Na ²		Na ²
Wait Delay Falling from IOWR	tdWT(IOWR)		35		35		Na ²		Na ²
IOWR High from Wait High ²	tdrIOWR(WT)	0		0		0			Na ²
Wait Width Time ²	tw(IORDY)		350		350		350		Na ¹

Notes: 1) -IOIS16 and -INPACK are not supported in this mode.

2) -WAIT is not supported in this mode.

3) The maximum load on -WAIT, -INPACK, and -IOIS16 is 1 LSTTL with 50 pF (40pF below 120nsec Cycle Time) total load. All times are in nanoseconds. Minimum time from -WAIT high to -IOWR high is 0 nsec, but minimum -IOWR width shall still be met. Din signifies data provided by the system to the CompactFlash Storage Card or CF+ Card. The Wait Width time meets the PCMCIA specification of 12 μs but is intentionally less in this specification.

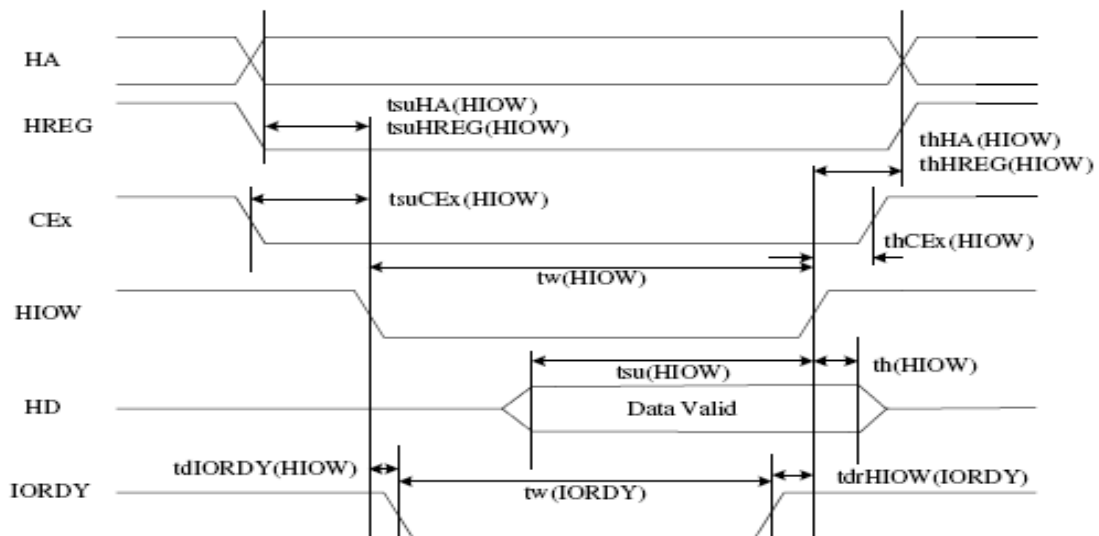

Figure 11: I/O Write Timing Diagram

4.2.7. True IDE PIO Mode Read/Write Timing

Table 19: True IDE PIO Mode Read/Write Timing

Item		Mode 0	Mode 1	Mode 2	Mode 3	Mode 4
t0	Cycle time (min) ¹	600	383	240	180	120
t1	Address Valid to HIOR/HIOW setup (min)	70	50	30	30	25
t2	HIOR/HIOW (min) ¹	165	125	100	80	70
t2	HIOR/HIOW (min) Register (8 bit) ¹	290	290	290	80	70
t2i	HIOR/HIOW recovery time (min) ¹	-	-	-	70	25
t3	HIOW data setup (min)	60	45	30	30	20
t4	HIOW data hold (min)	30	20	15	10	10
t5	HIOR data setup (min)	50	35	20	20	20
t6	HIOR data hold (min)	5	5	5	5	5
t6Z	HIOR data tristate (max) ²	30	30	30	30	30
t7	Address valid to IOCS16 assertion (max) ⁴	90	50	40	n/a	n/a
t8	Address valid to IOCS16 released (max) ⁴	60	45	30	n/a	n/a
t9	HIOR/HIOW to address valid hold	20	15	10	10	10
tRD	Read Data Valid to IORDY active (min), if IORDY initially low after tA	0	0	0	0	0
tA	IORDY Setup time ³	35	35	35	35	35
tB	IORDY Pulse Width (max)	1250	1250	1250	1250	1250
tC	IORDY assertion to release (max)	5	5	5	5	5

Notes:

All timings are in nanoseconds. The maximum load on IOCS16 is 1 LSTTL with a 50 pF (40pF below 120nsec Cycle Time) total load. All times are in nanoseconds. Minimum time from IORDY high to HIOE high is 0 nsec, but minimum HIOE width shall still be met. (1) t0 is the minimum total cycle time, t2 is the minimum command active time, and t2i is the minimum command recovery time or command inactive time. The actual cycle time equals the sum of the actual command active time and the actual command inactive time. The three timing requirements of t0, t2, and t2i shall be met. The minimum total cycle time requirement is greater than the sum of t2 and t2i. This means a host implementation can lengthen either or both t2 or t2i to ensure that t0 is equal to or greater than the value reported in the device's identify device data.

(2) This parameter specifies the time from the negation edge of HIOE to the time that the data bus is no longer driven by the device.

(3) The delay from the activation of HIOE or HIOW until the state of IORDY is first sampled. If IORDY is inactive then the host shall wait until IORDY is active before the PIO cycle can be completed. If the device is not driving IORDY negated at tA after the activation of HIOE or HIOW, then t5 shall be met and tRD is not applicable. If the device is driving IORDY negated at the time tA after the activation of HIOE or HIOW, then tRD shall be met and t5 is not applicable. (4) t7 and t8 apply only to modes 0, 1 and 2. For other modes, this signal is not valid. (5) IORDY is not supported in this mode.

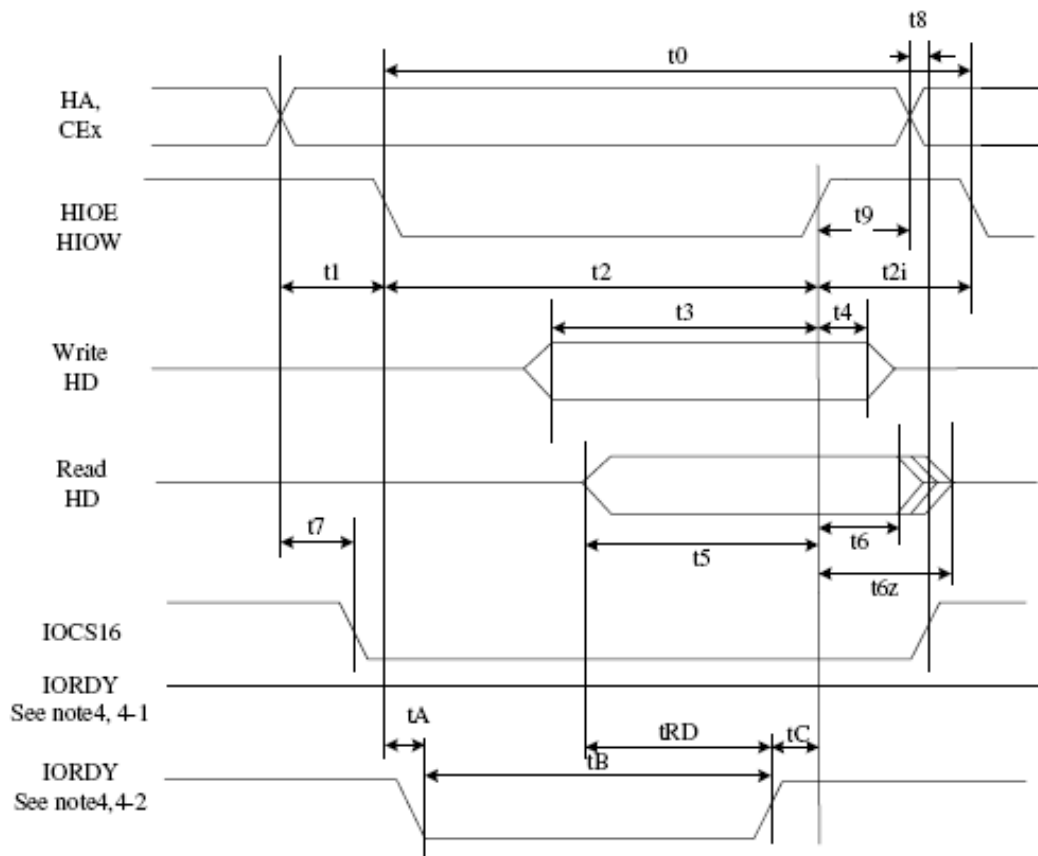

Figure 12: True IDE PIO Mode Read/Write Timing Diagram

Notes:

- 1) Device address consists of CE0, CE1, and HA [2:0]
- 2) Data consist of HD [15:00] (16-bit) or HD [7:0] (8-bit)
- 3) IOCS16 is shown for PIO modes 0, 1, and 2. For other modes, this signal is ignored.
- 4) The negation of IORDY by the device is used to extend the PIO cycle. The determination of whether the cycle is to be extended is made by the host after t_A from the assertion of HIOE or HIOW. The assertion and negation of IORDY is described in the following three cases:
 - 4-1) Device never negates IORDY: No wait is generated.
 - 4-2) Device drives IORDY low before t_A : wait generated. The cycle complete after IORDY is reasserted. For cycles where a wait is generated and HIOE is asserted, the device shall place read data on D15-D00 for t_{RD} before causing IORDY to be asserted.

4.2.8. True IDE Multiword DMA Mode Read/Write Timing

Table 20: True IDE Multiword DMA Mode Read/Write Timing

Item		Mode 0	Mode 1	Mode 2	Mode 3	Mode 4	Note
t_0	Cycle time (min)	480	150	120	100	80	1
t_D	HIOR / HIOW asserted width (min)	215	80	70	65	55	1
t_E	HIOR data access (max)	150	60	50	50	45	
t_F	HIOR data hold (min)	5	5	5	5	5	
t_G	HIOR/ HIOW data setup (min)	100	30	20	15	10	
t_H	HIOW data hold (min)	20	15	10	5	5	
t_I	DMACK(HREG) to HIOR/HIOW setup (min)	0	0	0	0	0	
t_J	HIOR / HIOW to -DMACK hold (min)	20	5	5	5	5	
t_{KR}	HIOR negated width (min)	50	50	25	25	20	1
t_{KW}	HIOW negated width (min)	215	50	25	25	20	1
t_{LR}	HIOR to DMARQ delay (max)	120	40	35	35	35	
t_{LW}	HIOW to DMARQ delay (max)	40	40	35	35	35	
t_M	CS1 CS0 valid to HIOR / HIOW	50	30	25	10	5	
t_N	CS1 CS0 hold	15	10	10	10	10	
t_Z	DMACK-	20	25	25	25	25	

Notes: t_0 is the minimum total cycle time and t_D is the minimum command active time, while t_{KR} and t_{KW} are the minimum command recovery time or command inactive time for input and output cycles respectively. The actual cycle time equals the sum of the actual command active time and the actual command inactive time. The three timing requirements of t_0 , t_D , t_{KR} , and t_{KW} shall be met. The minimum total cycle time requirement is greater than the sum of t_D and either of t_{KR} , and t_{KW} for input and output cycles respectively. This means a host implementation can lengthen either or both of t_D and either of t_{KR} , and t_{KW} as needed to ensure that t_0 is equal to or greater than the value reported in the device's identify device data. A device implementation shall support any legal host implementation.

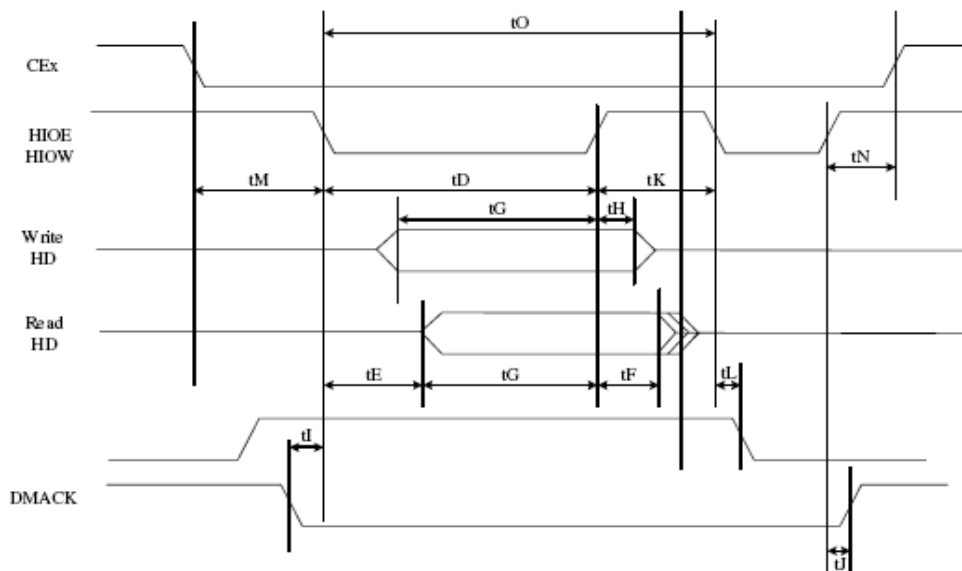

Figure 13: True IDE Multiword DMA Mode Read/Write Timing Diagram

Notes:

- 1) If the CompactFlash (CF) Card cannot sustain continuous, minimum cycle time DMA transfers, it may negate DMARQ within the time specified from the start of a DMA transfer cycle to suspend the DMA transfers in progress and reassert the signal at a later time to continue the DMA operation.
- 2) This signal may be negated by the host to suspend the DMA transfer in progress.

4.2.9. Ultra DMA Signal in Each Interface Mode

Table 21: Ultra DMA Signal in True IDE Mode

Signal	Type	(Non UDMA Memory Mode)	PC Card Memory Mode UDMA	PC Card IO Mode UDMA	TRUE IDE MODE UDMA
DMARQ	Output	(-INPACK)	-DMARQ	-DMARQ	DMARQ
HREG	Input	(-REG)	-DMARQ	DMARQ	-DMARQ
HIOW	Input	(-IOWR)	STOP ¹	STOP ¹	STOP ¹
HIOE	Input	(-IORD)	-HDMARDY(R) ^{1,2} HSTROBE(W) ^{1,3,4}	-HDMARDY(R) ^{1,2} HSTROBE(W) ^{1,3,4}	-HDMARDY(R) ^{1,2} HSTROBE(W) ^{1,3,4}
IORDY	Output	(-WAIT)	-DDMARDY(W) ^{1,3} DSTROBE(R) ^{1,2,4}	-DDMARDY(W) ^{1,3} DSTROBE(R) ^{1,2,4}	-DDMARDY(W) ^{1,3} DSTROBE(R) ^{1,2,4}
HD [15:00]	Bidir	(D [15:00])	D [15:00]	D [15:00]	D [15:00]
HA [10:00]	Input	(A [10:00])	A [10:00] ⁵	A [10:00] ⁵	A [02:00] ⁵
CSEL	Input	(-CSEL)	-CSEL	-CSEL	-CSEL
HIRQ	Output	(READY)	READY	-INTRQ	INTRQ
CE1	Input	(-CE1)	-CE1	-CE1	-CS0
CE2		(-CE2)	-CE2	-CE2	-CS1

Notes:

- 1) The UDMA interpretation of this signal is valid only during an Ultra DMA data burst.
- 2) The UDMA interpretation of this signal is valid only during an Ultra DMA data burst during a DMA Read command.
- 3) The UDMA interpretation of this signal is valid only during an Ultra DMA data burst during a DMA Write command.
- 4) The HSTROBE signals are active on both the rising and the falling edge.
- 5) Address lines 03 through 10 are not used in True IDE mode.

4.2.10. Ultra DMA Data Burst Timing Requirement

Table 22: Ultra DMA Data Burst Timing Requirement

Name	UDMA Mode 0		UDMA Mode 1		UDMA Mode 2		UDMA Mode 3		UDMA Mode 4		Measure Location2 (See Note 2)
	Min	Max	Min	Max	Min	Max	Min	Max	Min	Max	
t2CYCTYP	240		160		120		90		60		Sender
tCYC	112		73		54		39		25		Note3
t2CYC	230		153		115		86		57		Sender
tDS	15.0		10.0		7.0		7.0		5.0		Recipient
tDH	5.0		5.0		5.0		5.0		5.0		Recipient
tDVS	70.0		48.0		31.0		20.0		6.7		Sender
tDVH	6.2		6.2		6.2		6.2		6.2		Sender
tCS	15.0		10.0		7.0		7.0		5.0		Device
tCH	5.0		5.0		5.0		5.0		5.0		Device
tCVS	70.0		48.0		31.0		20.0		6.7		Host
tCVH	6.2		6.2		6.2		6.2		6.2		Host
tZFS	0		0		0		0		0		Device
tDZFS	70.0		48.0		31.0		20.0		6.7		Sender
tFS		230		200		170		130		120	Device
tLI	0	150	0	150	0	150	0	100	0	100	Note4
tMLI	20		20		20		20		20		Host
tUI	0		0		0		0		0		Host
tAZ		10		10		10		10		10	Note5
tZAH	20		20		20		20		20		Host
tZAD	0		0		0		0		0		Device
tENV	20	70	20	70	20	70	20	55	20	55	Host
tRFS		75		70		60		60		60	Sender
tRP	160		125		100		100		100		Recipient
tIORDYZ		20		20		20		20		20	Device
tZIORDY	0		0		0		0		0		Device
tACK	20		20		20		20		20		Host
tSS	50		50		50		50		50		Sender

Notes: All Timings in ns

- 1) All timing measurement switching points (low to high and high to low) shall be taken at 1.5 V.
- 2) All signal transitions for a timing parameter shall be measured at the connector specified in the measurement location column. For example, in the case of tRFS, both STROBE and -DMARDY transitions are measured at the sender connector.
- 3) The parameter tCYC shall be measured at the recipient's connector farthest from the sender.
- 4) The parameter tLI shall be measured at the connector of the sender or recipient that is responding to an incoming transition from the recipient or sender respectively. Both the incoming signal and the outgoing response shall be measured at the same connector.
- 5) The parameter tAZ shall be measured at the connector of the sender or recipient that is driving the bus but must release the bus to allow for a bus turnaround.
- 6) See the AC Timing requirements in 4.2.12. Ultra DMA AC Signal Requirements.

4.2.11. Ultra DMA Data Burst Timing Descriptions

Table 23: Ultra DMA Data Burst Timing Descriptions

Name	Comment	Notes
T2CYCTYP	Typical sustained average two cycle time	
tCYC	Cycle time allowing for asymmetry and clock variations (from STROBE edge to STROBE edge)	
t2CYC	Two cycle time allowing for clock variations (from rising edge to next rising edge or from falling edge next falling edge of STROBE)	
tDS	Data setup time at recipient (from data valid until STROBE edge)	2,5
tDH	Data hold time at recipient (from STROBE edge until data may become invalid)	2,5
tDVS	Data valid setup time at sender (from data valid until STROBE edge)	3
tDVH	Data valid hold time at sender (from STROBE edge until data may become invalid)	3
tCS	CRC word setup time at device	2
tCH	CRC word hold time device	2
tCVS	CRC word valid setup time at host (from CRC valid until -DMACK negation)	3
tCVH	CRC word valid hold time at sender (from -DMACK negation until CRC may become invalid)	3
tZFS	Time from STROBE output released-to-driving until the first transition of critical timing.	
tDZFS	Time from data output released-to-driving until the first transition of critical timing.	
tFS	First STROBE time (for device to first negate DSTROBE from STOP during a data in burst)	
tLI	Limited interlock time	1
tMLI	Interlock time with minimum	1
tUI	Unlimited interlock time	1
tAZ	Maximum time allowed for output drivers to release (from asserted or negated)	
tZAH	Minimum delay time required for output	
tZAD	drivers to assert or negate (from released)	
tENV	Envelope time (from -DMACK to STOP and -HDMARDY during data in burst initiation and from DMACK to STOP during data out burst initiation)	
tRFS	Ready-to-final-STROBE time (no STROBE edges shall be sent this long after negation of -DMARDY)	
tRP	Ready-to-pause time (that recipient shall wait to pause after negating -DMARDY)	
tIORDYZ	Maximum time before releasing IORDY	
tZIORDY	Minimum time before driving IORDY	4
tACK	Setup and hold times for -DMACK (before assertion or negation)	
tSS	Time from STROBE edge to negation of DMARQ or assertion of STOP (when sender terminates a burst)	

Notes:

- (1) The parameters tUI, tMLI (in Figure 16: Ultra DMA Data-In Burst Device Termination Timing and Figure 17: Ultra DMA Data-In Burst Host Termination Timing), and tLI indicate sender-to-recipient or recipient-to-sender interlocks, i.e., one agent (either sender or recipient) is waiting for the other agent to respond with a signal before proceeding. tUI is an unlimited interlock that has no maximum time value. tMLI is a limited time-out that has a defined minimum. tLI is a limited time-out that has a defined maximum.
- (2) 80-conductor cabling shall be required in order to meet setup (tDS, tCS) and hold (tDH, tCH) times in modes greater than 2.
- (3) Timing for tDVS, tDVH, tCVS and tCVH shall be met for lumped capacitive loads of 15 and 40 pF at the connector where the Data and STROBE signals have the same capacitive load value. Due to reflections on the cable, these timing measurements are not valid in a normally functioning system.
- (4) For all timing modes the parameter tZIORDY may be greater than tENV due to the fact that the host has a pull-up on IORDY- giving it a known state when released.
- (5) The parameters tDS, and tDH for mode 5 are defined for a recipient at the end of the cable only in a configuration with a single device located at the end of the cable. This could result in the minimum values for tDS and tDH for mode 5 at the middle connector being 3.0 and 3.9 ns respectively.

4.2.12. Ultra DMA Sender and Recipient IC Timing Requirements

Table 24: Ultra DMA Sender and Recipient IC Timing Requirements

Name	UDMA Mode 0		UDMA Mode 1		UDMA Mode 2		UDMA Mode 3		UDMA Mode 4	
	Min	Max	Min	Max	Min	Max	Min	Max	Min	Max
tDSIC	14.7		9.7		6.8		6.8		4.8	
tDHIC	4.8		4.8		4.8		4.8		4.8	
tDVSIC	72.9		50.9		33.9		22.6		9.5	
tDVHIC	9.0		9.0		9.0		9.0		9.0	
tDSIC	Recipient IC data setup time (from data valid until STROBE edge) (see note 2)									
tDHIC	Recipient IC data hold time (from STROBE edge until data may become invalid) (see note 2)									
tDVSIC	Sender IC data valid setup time (from data valid until STROBE edge) (see note 3)									
tDVHIC	Sender IC data valid hold time (from STROBE edge until data may become invalid) (see note 3)									

Notes:

- (1) All timing measurement switching points (low to high and high to low) shall be taken at 1.5 V.
- (2) The correct data value shall be captured by the recipient given input data with a slew rate of 0.4 V/ns rising and falling and the input STROBE with a slew rate of 0.4 V/ns rising and falling at tDSIC and tDHIC timing (as measured through 1.5 V).
- (3) The parameters tDVSIC and tDVHIC shall be met for lumped capacitive loads of 15 and 40 pF at the IC where all signals have the same capacitive load value. Noise that may couple onto the output signals from external sources has not been included in these values.

4.2.13. Ultra DMA AC Signal Requirements

Table 25: Ultra DMA AC Signal Requirements

Name	Comment	Min [V/ns]	Max [V/ns]	Notes
SRISE	Rising Edge Slew Rate for any signal		1.25	1
SFALL	Falling Edge Slew Rate for any signal		1.25	1

Notes:

- (1) The sender shall be tested while driving an 18 inch long, 80 conductor cable with PVC insulation material. The signal under test shall be cut at a test point so that it has not trace, cable or recipient loading after the test point. All other signals should remain connected through to the recipient. The test point may be located at any point between the sender's series termination resistor and one half inch or less of conductor exiting the connector. If the test point is on a cable conductor rather than the PCB, an adjacent ground conductor shall also be cut within one half inch of the connector. The test load and test points should then be soldered directly to the exposed source side connectors. The test loads consist of a 15 pF or a 40 pF, 5%, 0.08 inch by 0.05 inch surface mount or smaller size capacitor from the test point to ground. Slew rates shall be met for both capacitor values. Measurements shall be taken at the test point using a <1 pF, >100 Kohm, 1 Ghz or faster probe and a 500 MHz or faster oscilloscope. The average rate shall be measured from 20% to 80% of the settled VOH level with data transitions at least 120 nsec apart. The settled VOH level shall be measured as the average output high level under the defined testing conditions from 100 nsec after 80% of a rising edge until 20% of the subsequent falling edge.

4.2.14. Ultra DMA Data-In Burst Initiation Timing

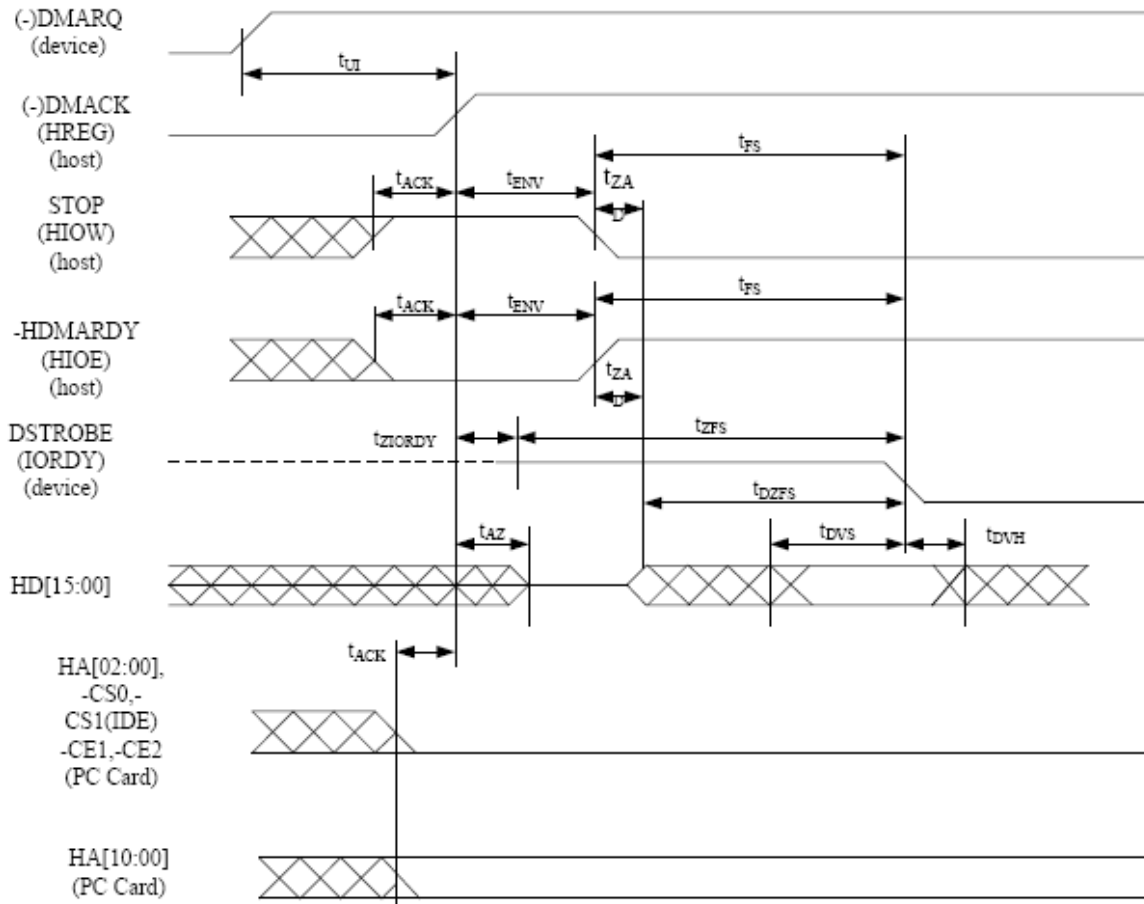

Figure 14: Ultra DMA Data-in Burst Initiation Timing Diagram

ALL WAVEFORMS IN THIS DIAGRAM ARE SHOWN WITH THE ASSERTED STATE HIGH.
 NEGATIVE TRUE SIGNALS APPEAR INVERTED ON THE BUS RELATIVE TO THE DIAGRAM.
 Notes: The definitions for the IORDY:-DDMARDY: DSTROBE,-IORD:-HDMARDY: HSTROBE,
 and -IOWR:STOP signal lines are not in effect until DMARQ and -DMACK are asserted.
 HA [02:00] , -CS0 & -CS1 are True IDE mode signal definitions. HA [10:00] , -CE1 and -CE2
 are PC Card mode signals. The Bus polarity of (-) DMACK and (-) DMARQ are dependent
 on interface mode active.

4.2.15. Sustained Ultra DMA Data-In Burst Timing

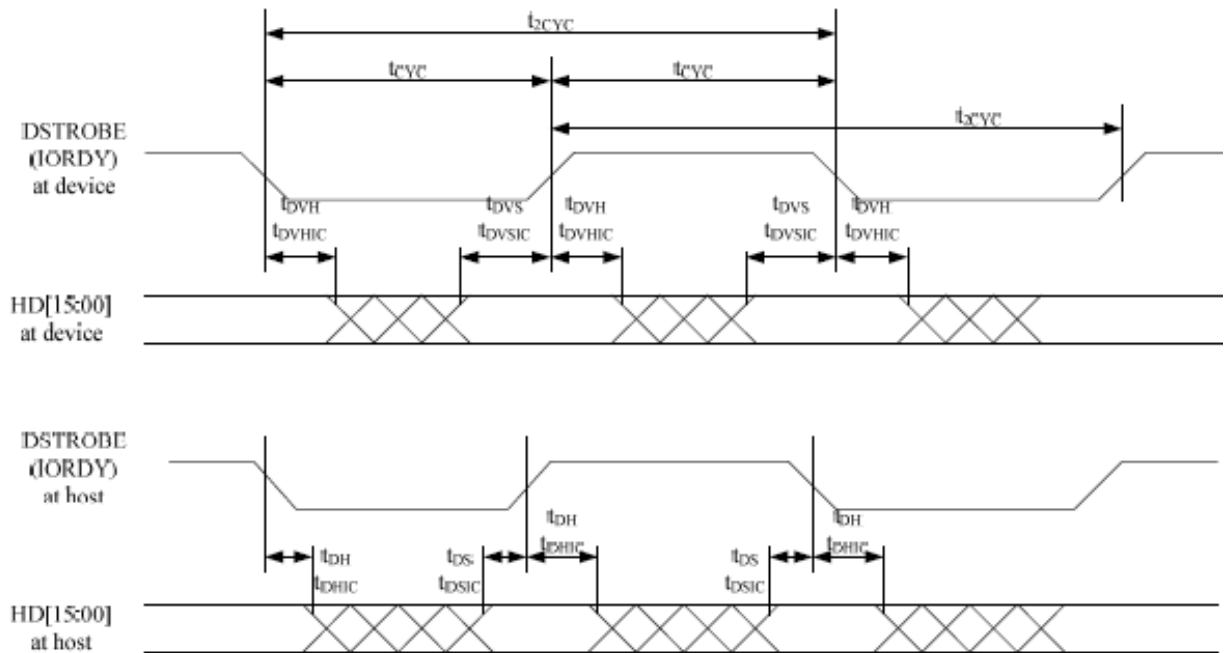

Figure 15: Sustained Ultra DMA Data-in Burst Initiation Timing Diagram

Note:

HD [15:00] and DSTROBE signals are shown at both the host and the device to emphasize that cable setting time as well as cable propagation delay shall not allow the data signals to be considered stable at the host until some time after they are driven by the device.

4.2.16. Ultra DMA Data-In Burst Host Pause Timing

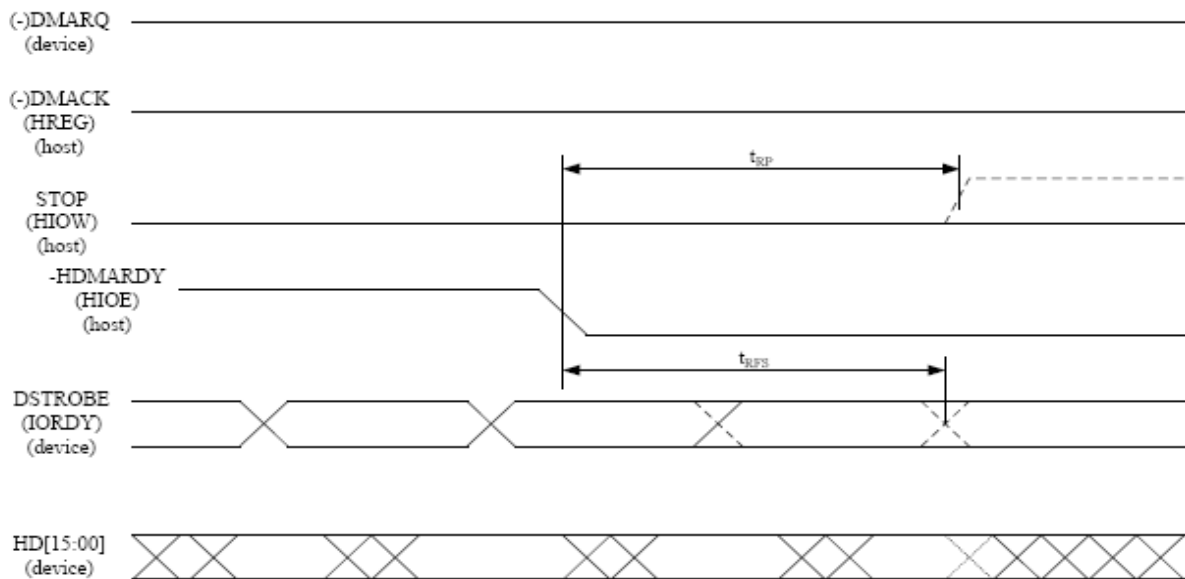

Figure 16: Ultra DMA Data-In Burst Host Pause Timing Diagram

ALL WAVEFORMS IN THIS DIAGRAM ARE SHOWN WITH THE ASSERTED STATE HIGH. NEGATIVE TRUE SIGNALS APPEAR INVERTED ON THE BUS RELATIVE TO THE DIAGRAM.

Notes:

- (1) The host may assert STOP to request termination of the Ultra DMA data burst no sooner than t_{RP} after -HDMARDY is negated.
- (2) After negating -HDMARDY , the host may receive zero, one, two, or three more data words from the device.
- (3) The bus polarity of the (-) DMARQ and (-) DMACK signals is dependent on the active interface mode.

4.2.17. Ultra DMA Data-In Burst Device Termination Timing Diagram

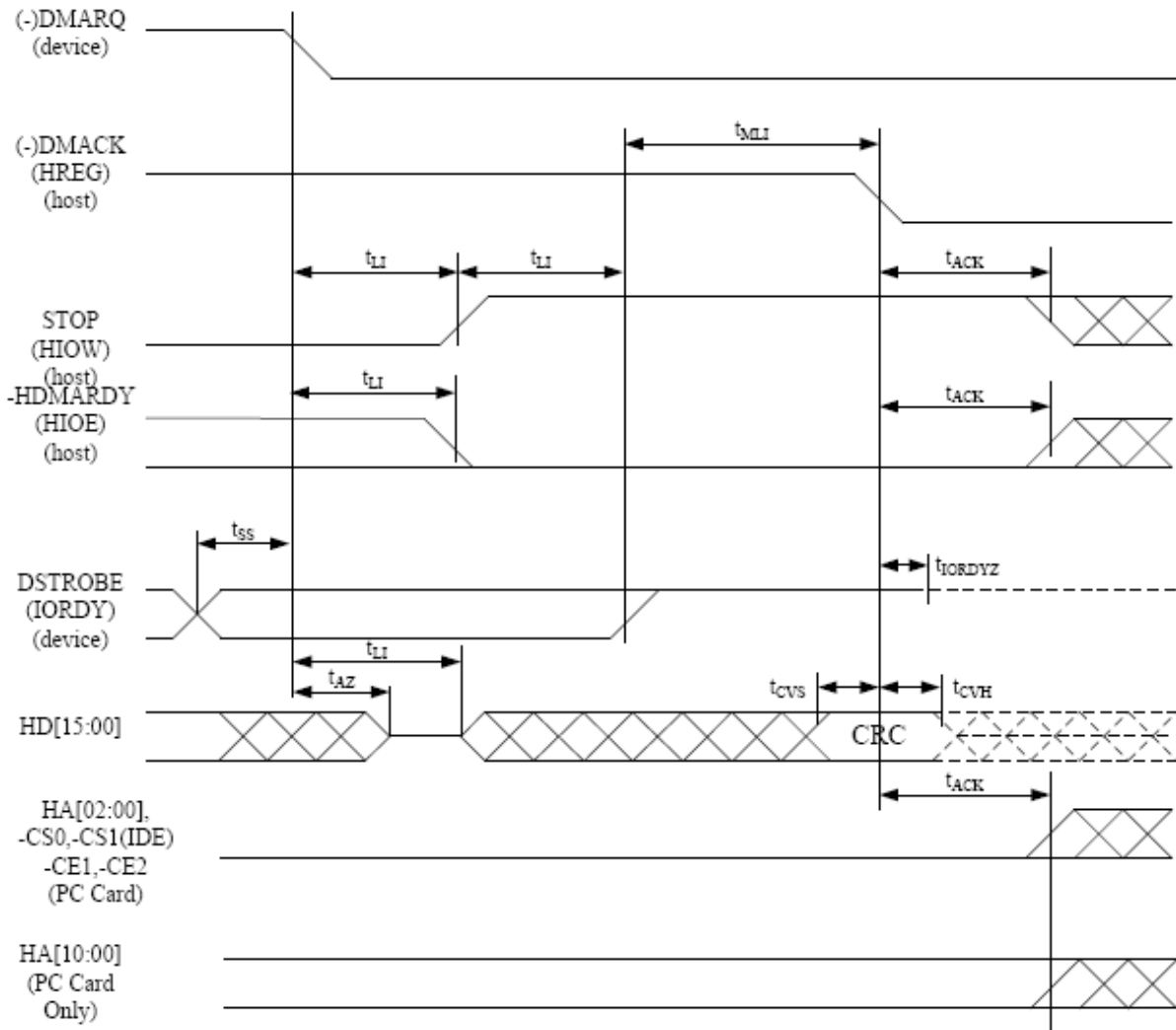

Figure 17: Ultra DMA Data-In Burst Device Termination Timing Diagram

ALL WAVEFORMS IN THIS DIAGRAM ARE SHOWN WITH THE ASSERTED STATE HIGH. NEGATIVE TRUE SIGNALS APPEAR INVERTED ON THE BUS RELATIVE TO THE DIAGRAM.

Notes: The definitions for the STOP, HDMARDY, and DSTROBE signal lines are no longer in effect after DMARQ and DMACK are negated. HA[02:00], -CS0 & -CS1 are True IDE mode signal definitions. HA[10:00], -CE1 and -CE2 are PC Card mode signals. The bus polarity of DMARQ and DMACK are dependent on the active interface mode.

4.2.18. Ultra DMA Data-In Burst Host Termination Timing

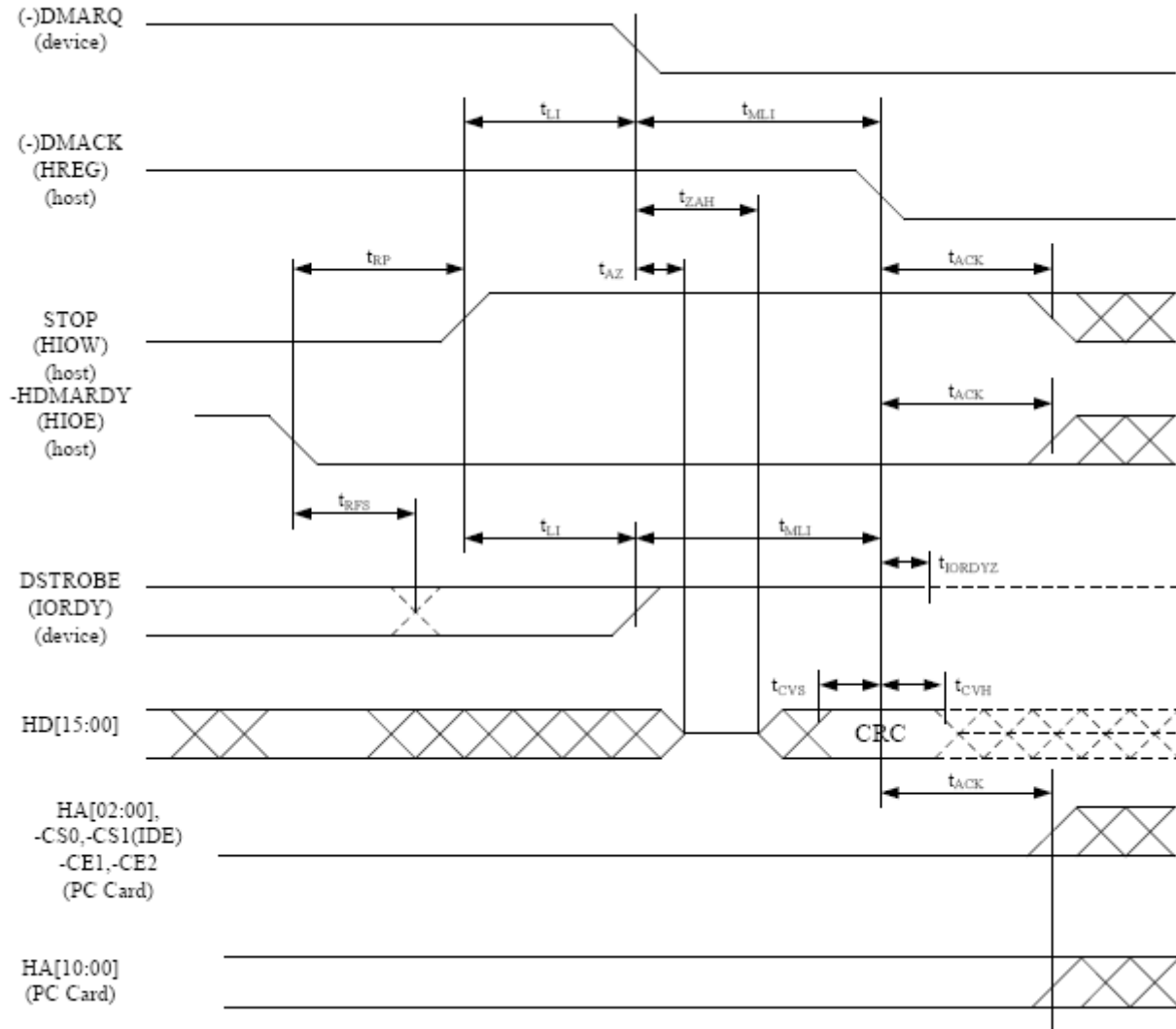

Figure 18: Ultra DMA Data-In Burst Host Termination Timing Diagram

ALL WAVEFORMS IN THIS DIAGRAM ARE SHOWN WITH THE ASSERTED STATE HIGH. NEGATIVE TRUE SIGNALS APPEAR INVERTED ON THE BUS RELATIVE TO THE DIAGRAM.

Notes: The definitions for the STOP, HDMARDY, and DSTROBE signal lines are no longer in effect after DMARQ and DMACK are negated. HA[02:00], -CS0 & -CS1 are True IDE mode signal definitions. HA[10:00], -CE1 and -CE2 are PC Card mode signals. The bus polarity of DMARQ and DMACK are dependent on the active interface mode.

4.2.20. Sustained Ultra DMA Data-Out Burst Host Initiation Timing

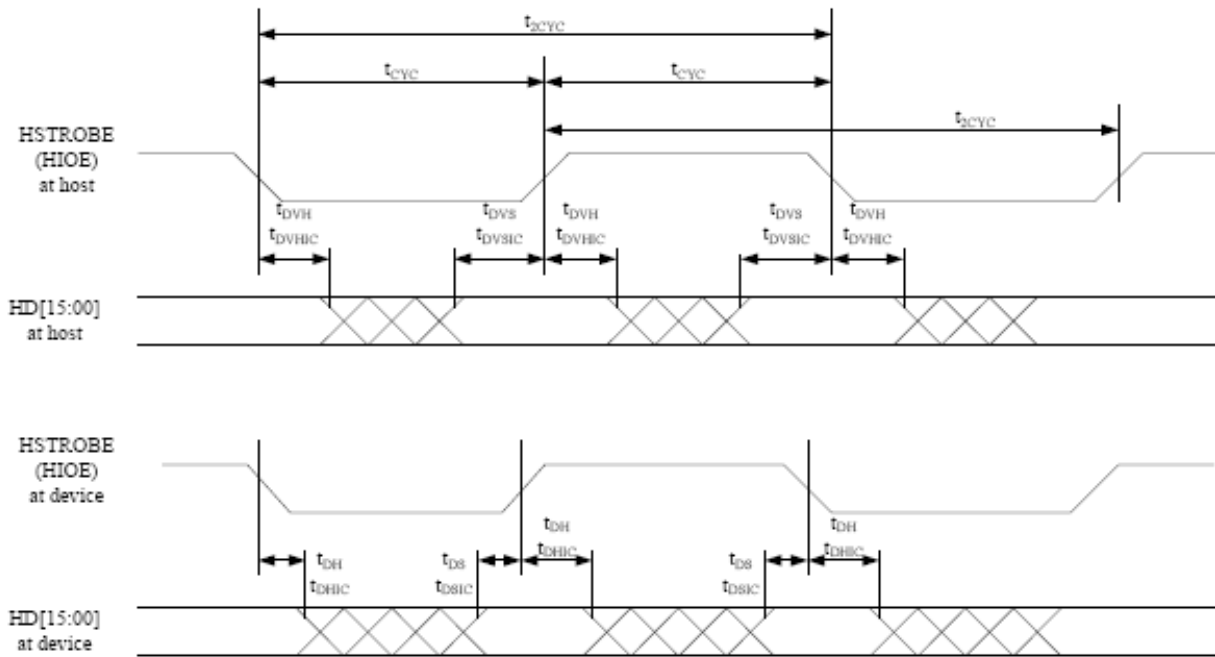

Figure 20: Sustained Ultra DMA Data-Out Burst Timing Diagram

Notes: Data (HD[15:00]) and HSTROBE signals are shown at both the device and the host to emphasize that cable setting time as well as cable propagation delay shall not allow the data signals to be considered stable at the device until some time after they are driven by the host.

4.2.21. Ultra DMA Data-Out Burst Device Pause Timing

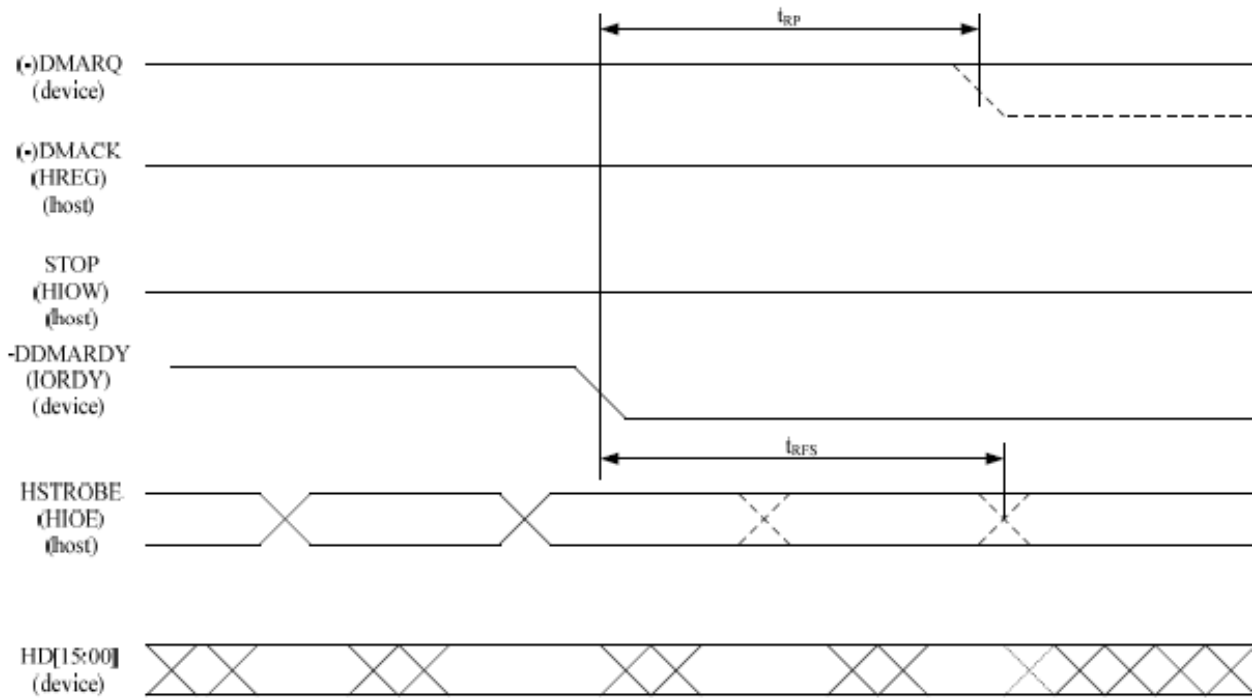

Figure 21: Ultra DMA Data-out Burst Device Pause Timing Diagram

ALL WAVEFORMS IN THIS DIAGRAM ARE SHOWN WITH THE ASSERTED STATE HIGH. NEGATIVE TRUE SIGNALS APPEAR INVERTED ON THE BUS RELATIVE TO THE DIAGRAM.

Notes: (1) The device may negate DMARQ to request termination of the Ultra DMA data burst no sooner than t_{RP} after -DDMARDY , is negated.

(2) After negating -DDMARDY , the device may receive zero, one, two, or three more data words from the host.

(3) The bus polarity of DMARQ and DMACK depend on the active interface mode.

4.2.22. Ultra DMA Data-Out Burst Device Termination Timing

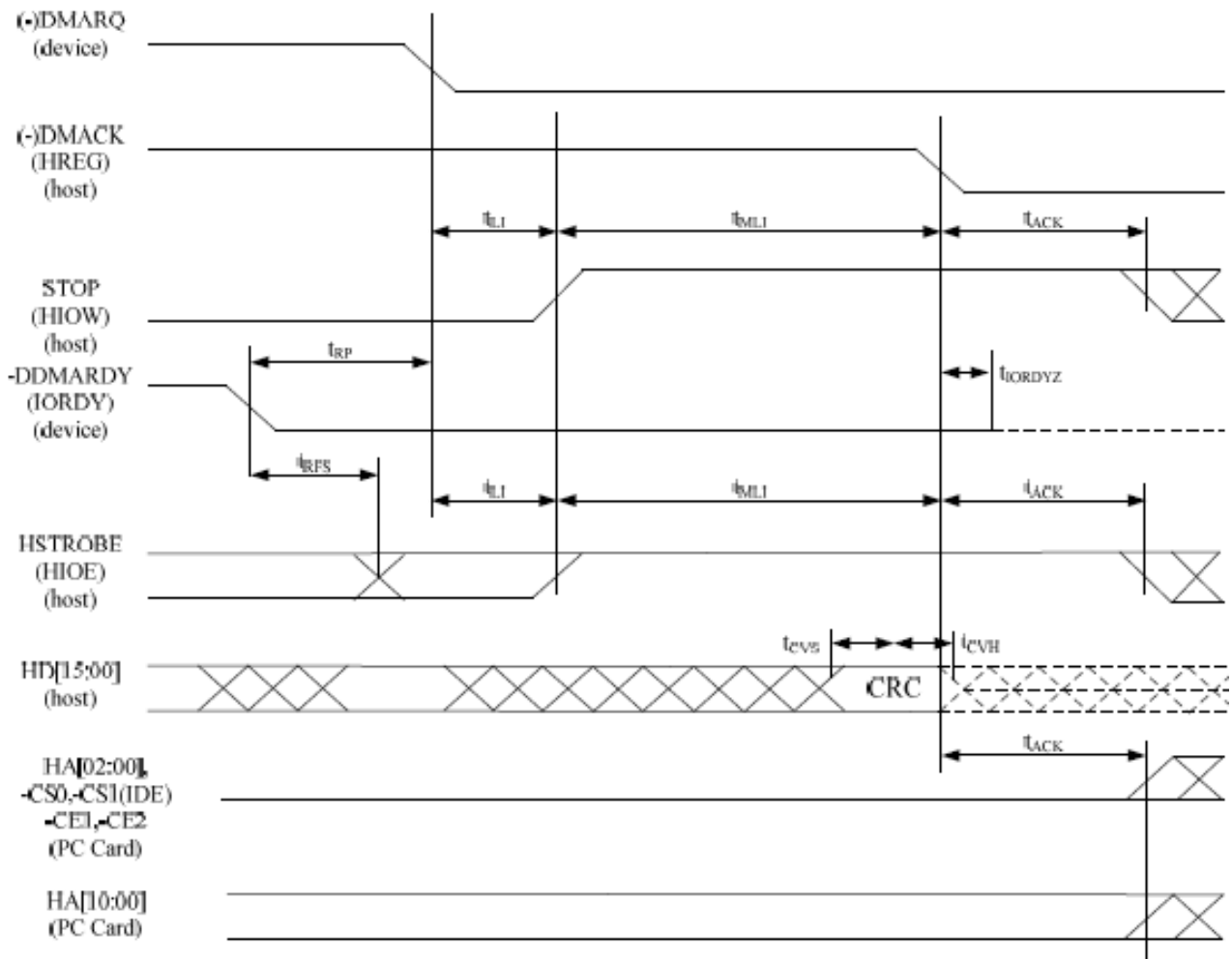

Figure 22: Ultra DMA Data-Out Burst Device Termination Timing Diagram

ALL WAVEFORMS IN THIS DIAGRAM ARE SHOWN WITH THE ASSERTED STATE HIGH. NEGATIVE TRUE SIGNALS APPEAR INVERTED ON THE BUS RELATIVE TO THE DIAGRAM.

Notes: The definitions for the STOP, HDMARDY, and DSTROBE signal lines are no longer in effect after DMARQ and DMACK are negated. HA[00:02], -CS0 & -CS1 are True IDE mode signal definitions. HA[00:10], -CE1 and -CE2 are PC Card mode signals. The bus polarity of DMARQ and DMACK are dependent on the active interface mode.

4.2.23. Ultra DMA Data-Out Burst Host Termination Timing

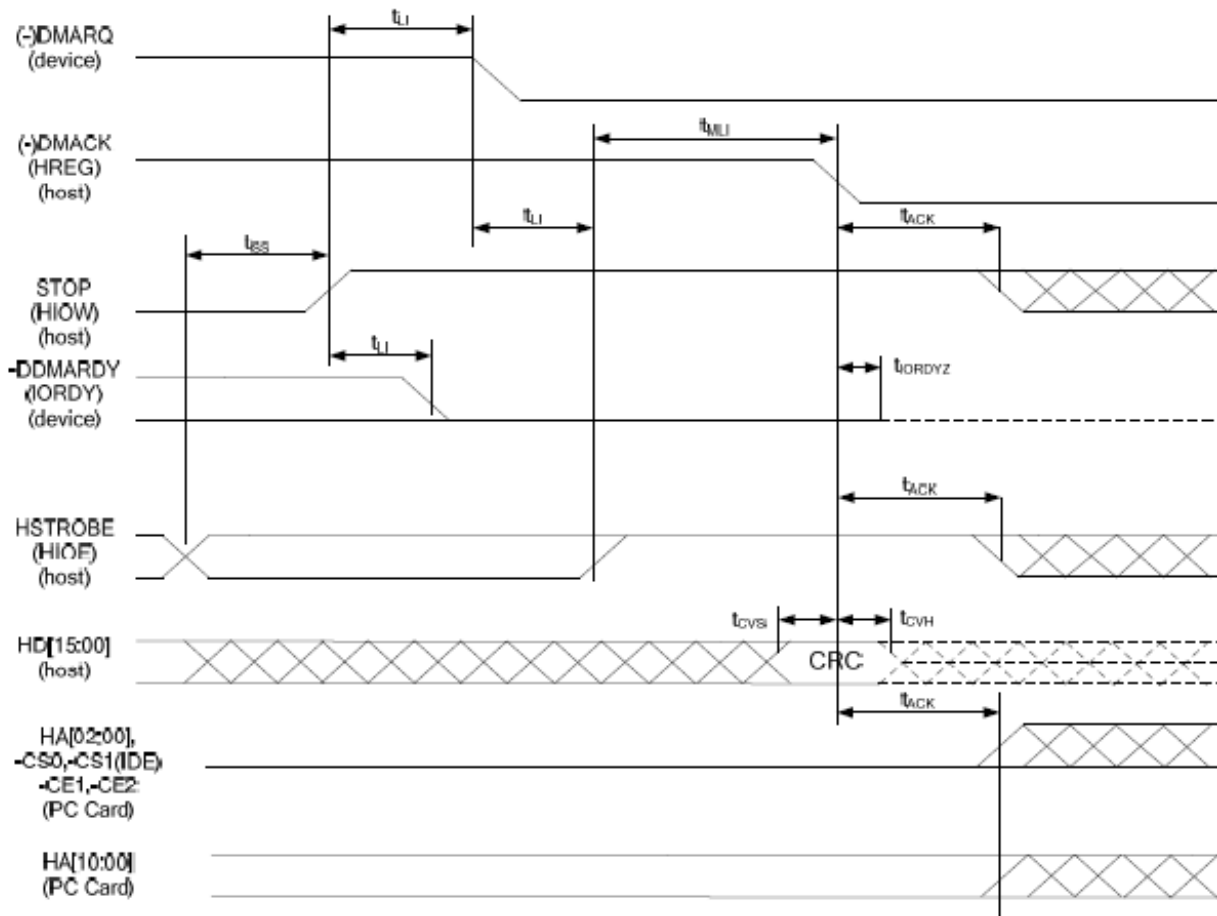

Figure 23: Ultra DMA Data-Out Burst Host Termination Timing Diagram

ALL WAVEFORMS IN THIS DIAGRAM ARE SHOWN WITH THE ASSERTED STATE HIGH. NEGATIVE TRUE SIGNALS APPEAR INVERTED ON THE BUS RELATIVE TO THE DIAGRAM.

Notes: The definitions for the STOP, HDMARDY, and DSTROBE signal lines are no longer in effect after DMARQ and DMACK are negated. HA[02:00], -CS0 & -CS1 are True IDE mode signal definitions. HA[10:00], -CE1 and -CE2 are PC Card mode signal definitions. The bus polarity of DMARQ and DMACK are dependent on the active interface mode.

5. Interface Register Definition

5.1. Device Address

This controller receives commands from the host only when it is the selected device by checking the DEV bit in the Device Register.

This interface is for the host to program and perform commands and return status.

Table 26: Device Address Commands

CS1-	CS0-	A2	A1	A0	DMACK-	DIOR- = L	DIOW- = L
1	0	0	0	0	X	Data register	Data register
1	1	X	X	X	0	DMA Data RD	DMA Data Write
1	0	0	0	1	X	Error register	Feature register
1	0	0	1	0	X	Sector Count register	Sector Count register
1	0	0	1	1	X	LBA Low register	LBA Low register
1	0	1	0	0	X	LBA Mid register	LBA Mid register
1	0	1	0	1	X	LBA High register	LBA High register
1	0	1	1	0	X	Device register	Device register
1	0	1	1	1	X	Status register	Command register
0	1	1	1	0	X	Alt. Status register	Device Control register

5.2. I/O Register Descriptions

The Command Block registers are used for the host to send commands to this controller or for this controller to post status. These registers include the LBA High, LBA Mid, LBA Low, Device, Sector Count, Command, Status, Features, Error and Data Registers. The Control Block register is used for device control and to post alternate status. These registers include Device Control and Alternate Status registers.

For the detail field/bit description of every register, please refer to the ATAPI-5 specification.

(4) Alternate Status Register

This register contains the same information as the Status register in the Command Block.

(5) Command Register

This register contains the command code being sent. This controller begins immediately to execute the command after receipt of the command

(6) DMA Data Port

This port is only accessed for the host DMA data transfers when DMACK- and DMARQ are asserted. The data is 16-bits in width.

(7) Data Register

This register is accessed for the host PIO data transfer only when DRQ is set to one and DMACK– is not asserted. The contents of this register are not valid while it is in the Sleep mode. This register is 16 bits wide.

(8) Device Register

This register is for the host to set bit 4, DEV, of this register to select the device. Other bits in this register are command dependent.

(9) Device Control Register

This register allows the host to software reset attached devices and to enable or disable the assertion of the INTRQ signal by a selected device. When this register is written, the controller will respond to the write no matter the device is selected or not. And this controller will respond to the SRST bit when in the SLEEP mode.

(10) Error Register

At command completion of any command, the contents of this register are valid when the ERR bit is set to one in the Status register.

(11) Feature Register

This register is writing only. If this address is read by the host, the content read by the host will be the Error register.

The content of this register is command dependent.

(12) LBA High Register

This register contains the high order bits of logic block address and becomes a command parameter when Command register is written.

(13) LBA Low Register

This register contains the low order bits of logic block address and becomes a command parameter when Command register is written.

(14) LBA Mid Register

This register contains bit 15-8 of logic block address and becomes a command parameter when Command register is written.

(15) Sector Count Register

This register contains the numbers of sectors of data requested to be transferred on a read or write operation.

(16) Status Register

This register contains the device status. The contents of this register are updated to reflect the current state of the device.

6. Software Specification

6.1. ATA Command Set

The following table summarizes the commands supported by the controller.

	Command	Code	FR	SC	SN	CY	DH	LBA	Controller Status	Note
1	Check Power Mode	E5 or 98h	–	–	–	–	Y	–	Support	
2	Execute Drive Diagnostic	90h	–	–	–	–	Y	–	Support	
3	Erase Sector	C0h	–	Y	Y	Y	Y	Y	Support	
4	Flush Cache	E7h	–	–	–	–	Y	–	NOT Support	#4
5	Format Track	50h	–	Y	–	Y	Y	Y	Support	
6	Identify Device	Ech	–	–	–	–	Y	–	Support	
7	Idle	E3h or 97h	–	Y	–	–	Y	–	Support	
8	Idle Immediate	E1h or 95h	–	–	–	–	Y	–	Support	
9	Initialize Drive Parameters	91h	–	Y	–	–	Y	–	Support	
10	Key Management Structure Read	B9 (Feature 0-127)	Y	Y	Y	Y	Y	–	NOT Support	#1
11	Key Management Read Keying Material	B9 (Feature 80)	Y	Y	Y	Y	Y	–	NOT Support	#1
12	Key Management Change Key Management Value	B9 (Feature 81)	Y	Y	Y	Y	Y	–	NOT Support	#1
13	NOP	00h	–	–	–	–	Y	–	Support	
14	Read Buffer	E4h	–	–	–	–	Y	–	Support	
15	Read DMA	C8h	–	Y	Y	Y	Y	Y	Support	
16	Read Long Sector	22h or 23h	–		Y	Y	Y	Y	NOT Support	#3
17	Read Multiple	C4h	–	Y	Y	Y	Y	Y	Support	
18	Read Sector(s)	20h or 21h	–	Y	Y	Y	Y	Y	Support	
19	Read Verify Sector(s)	40h or 41h	–	Y	Y	Y	Y	Y	Support	
20	Recalibrate	1Xh	–	–	–	–	Y	–	Support	
21	Request Sense	03h	–	–	–	–	Y	–	Support	
22	Security Disable Password	F6h	–	–	–	–	Y	–	NOT Support	#2, #5
23	Security Erase Prepare	F3h	–	–	–	–	Y	–	NOT Support	#2, #5

	Command	Code	FR	SC	SN	CY	DH	LBA	Controller Status	Note
2 4	Security Erase Unit	F4h	-	-	-	-	Y	-	NOT Support	#2, #5
2 5	Security Freeze Lock	F5h	-	-	-	-	Y	-	NOT Support	#2, #5
2 6	Security Set Password	F1h	-	-	-	-	Y	-	NOT Support	#2, #5
2 7	Security Unlock	F2h	-	-	-	-	Y	-	NOT Support	#2, #5
2 8	Seek	7Xh	-	-	Y	Y	Y	Y	Support	
2 9	Set Feature	EFh	Y	-	-	-	Y	-	Support	
3 0	Set Multiple Mode	C6h	-	Y	-	-	Y	-	Support	
3 1	Set Sleep Mode	E6h or 99h	-	-	-	-	Y	-	Support	
3 2	Standby	E2 or 96h	-	-	-	-	Y	-	Support	
3 3	Standby Immediate	E0 or 94h	-	-	-	-	Y	-	Support	
3 4	Translate Sector	87h	-	Y	Y	Y	Y	Y	Support	
3 5	Wear Level	F5h	-	-	-	-	Y	-	Support	
3 6	Write Buffer	E8h	-	-	-	-	Y	-	Support	
3 7	Write DMA	CAh	-	Y	Y	Y	Y	Y	Support	
3 8	Write Long Sector	32h or 33h	-	-	Y	Y	Y	Y	Not Support	#3
3 9	Write Multiple	C5h	-	Y	Y	Y	Y	Y	Support	
4 0	Write Multiple w/o Erase	CDh	-	Y	Y	Y	Y	Y	Support	
4 1	Write Sector(s)	30h or 31h	-	Y	Y	Y	Y	Y	Support	
4 2	Write Sector(s) w/o Erase	38h	-	Y	Y	Y	Y	Y	Support	
4 3	Write Verify	3Ch	-	Y	Y	Y	Y	Y	Support	

Notes:

- 1) *These commands are optional, depending on the key Management scheme in use.*
- 2) *Use of this command is not recommended by CFA.*

-
- 3) *Use of this command is not recommended.*
 - 4) *SM223 don't have cache.*
 - 5) *Will support by firmware update, it will be available by September, 2008*
 - 6) **Definitions**

FR = Features Register

SC =Sector Count register (00H to FFH, 00H means 256 sectors) S

N = Sector Number register

CY = Cylinder Low/High register

DH = Head No. (0 to 15) of Drive/Head register

LBA = Logic Block Address Mode Support

- = Not used for the command

Y = Used for the command

6.2. ATA Command Description

(1) CFA Erase Sector(s) – C0h

This command pre-erases and conditions from 1 to 256 sectors in the Sector Count register. This command must be issued in advance of CFA Write without Erase or CFA Write Multiple without Erase command to increase the execution speed of the write operation.

(2) CFA Request Extended Error Code – 03h

This command requests extended error information for the previous command. The extended error code is returned to the host in the Error Register.

(3) CFA Translate Sector – 87h

This command allows the host a method of determining the exact times a user sector has been erased and programmed. This controller will respond with a 512-byte buffer of information containing the desired cylinder, head and sector, including its Logical Address.

(4) CFA Write Multiple w/o Erase – CDh

This command is similar to Write Multiple command with the exception that an implied erase before write operation is not performed.

(5) Write Sector(s) w/o Erase – 38h

This command is similar to the Write Sector(s) command with the exception that an implied erase before write operation is not performed.

(6) Check Power Mode – E5h

This command allows the host to determine the current power mode of the device. This command will not cause this controller to change power mode.

(7) Execute Device Diagnostic – 90h

This command causes the controller to perform the internal diagnostic tests.

(8) Identify Device – ECh

This command enables the host to receive parameter information from the device. The following table specifies each field in the data returned by Identify Device command.

Table 27: Identify Device Commands

Word address	F/V ¹	Description	Value
0	F X F X	General configuration bit-significant information: 15 0 = ATA device 14-8 Reserved. 7 0 = the device is a fixed disk 6-0 Reserved.	045Ah
1	V	Number of logical cylinders	xxxxh ¹
2	V	Specific configuration	0000h
3	F	Number of logical heads	xxxxh
4 - 5	X	Reserved	xxxxh
6	F	Number of logical sectors per logical track	xxxxh
7 - 8	X	Reserved	xxxxh
9	X	Reserved	0000h
10 to 19	C	Serial number (20 ASCII characters)	aaaa ²
20	X	Reserved	0001h
21 - 22	X	Reserved	0004h
23 - 26	F	Firmware revision (8 ASCII characters)	aaaa
27 - 46	C	Model number (40 ASCII characters)	aaaa
47	F F	15-8 80h 7-0 01h = Maximum number of sector on Read/Write Multiple command	8001h
48	F	Reserved	0000h
49	F F F F F F X	Capabilities 15-14 Reserved 13 0 = Standby timer is managed by this controller 12 Reserved 11 1 = IORDY supported. 10 1 = IORDY may be disabled. 9 1 = LBA mode addressing supported. 8 1 = DMA supported. 7 - 0 Reserved	0F00h
50	F	15- 0 0000h = the contents of word 50 is not valid.	0000h
51	F	Reserved.	0200h
52	X	Reserved	0000h
53	F F F	15- 3 Reserved. 2 1 = the field reported in word 88 are valid 1 1 = the field reported in word (70:64) are valid 0 1 = the field reported in word 54-58 are valid	0007h
54	V	Number of current logical cylinders	xxxxh
55	V	Number of current logical heads	xxxxh

56	V	Number of current logical sectors per track	xxxxh
57- 58	V	Current capacity in sectors	xxxxh
59	F V V	15- 9 Reserved 8 1 = multiple sector setting is valid 7- 0 xxh = current setting for number of sectors that is transferred per interrupt on R/W Multiple commands.	0101h
60 - 61	F	Total number of user addressable sectors	xxxxh
62	X	Reserved	0000h
63	F V F F F F	15-11 Reserved. 10- 8 Multiword DMA mode 2-0 selected. 7- 3 Reserved. 2 1 = Multiword DMA mode 2,1 and 0 are supported. 1 1 = Multiword DMA mode 1 and 0 are supported. 0 1 = Multiword DMA mode 0 is supported.	0407h
64	F C F	15- 2 Reserved 1 1 = PIO mode 4 is supported. 0 1 = PIO mode 3 is supported.	0003h
65	F	15- 0 0078h = minimum Multiword DMA transfer cycle time = 120 nano seconds.	0078h
66	F	15- 0 0078h = recommended Multiword DMA transfer cycle time = 120 nano seconds.	0078h
67	F	15- 0 0078h = minimum PIO transfer cycle time without flow control = 120 nano seconds.	0078h
68	F	15- 0 0078h = minimum PIO transfer cycle time with IORDY flow control = 120 nano seconds.	0078h
69 - 79	F	Reserved	0000h
80	F	15- 0 0000h = Major version number is not reported.	0000h
81	F	15- 0 0000h = Minor version number is not reported.	0000h
82	X F F F X F F F F F F F F F	Command set supported. 15 Reserved. 14 1 = NOP command supported. 13 1 = READ BUFFER command supported. 12 1 = WRITE BUFFER command supported. 11 Reserved. 10 1 = Host Protected Area feature set supported. 9 1 = DEVICE RESET command supported. 8 1 = SERVICE interrupt supported. 7 1 = release interrupt supported. 6 1 = look-ahead supported. 5 1 = write cache supported. 4 1 = Shall be cleared to zero. 3 1 = mandatory power management feature set supported. 2 1 = Removable Media feature set supported. 1 1 = Security Mode feature set supported.	3000h

	F	0 1 = SMART feature set supported.	
83 - 84	F	15- 0 0000h = features/command sets supported are not indicated.	0000h
85	X F F F X V F V V V V F F F V V	Command set/ feature enabled. 15 Reserved. 14 1 = NOP command enabled. 13 1 = READ BUFFER command enabled. 12 1 = WRITE BUFFER command enabled. 11 Reserved. 10 1 = Host Protected Area feature set enabled. 9 1 = DEVICE RESET command enabled. 8 1 = SERVICE interrupt enabled. 7 1 = release interrupt enabled. 6 1 = look-ahead enabled. 5 1 = write cache enabled. 4 1 = Shall be cleared to zero. 3 1 = power management feature set enabled. 2 1 = Removable Media feature set enabled. 1 1 = Security Mode feature set enabled. 0 1 = SMART feature set enabled.	3000h
85 - 87	F	15- 0 0000h = features/command sets enabled are not indicated.	0000h
88	F V V V V V F C F C F C	15-13 Reserved. 12 1 = Ultra DMA mode 4 is selected 11 1 = Ultra DMA mode 3 is selected. 10 1 = Ultra DMA mode 2 is selected 9 1 = Ultra DMA mode 1 is selected. 8 1 = Ultra DMA mode 0 is selected. 7- 5 Reserved 4 1 = Ultra DMA mode 4 and below are supported. 3 1 = Ultra DMA mode 3 and below are supported. 2 1 = Ultra DMA mode 2 and below are supported. 1 1 = Ultra DMA mode 1 and below are supported. 0 1 = Ultra DMA mode 0 is supported.	001Fh
89	F	Time required for security erase unit completion. 15- 0 0000h = value not specified.	0000h
90	F	Time required for Enhanced security erase unit completion. 15- 0 0000h = value not specified.	0000h
91	V	Current advanced power management value 15- 0 0000h = value not specified.	0000h
92	V	Master Password Revision Code.	0000h
93	V	Reserved.	0000h
94	V	15- 0 0000h = Automatic Acoustic Management feature set is not supported.	0000h
95 - 99	F	Reserved	0000h
100 - 103	V	The 48-bit Address feature set is not supported.	0000h

104 - 126	F	Reserved.	0000h
127	F F	Removable Media Status Notification feature set support 15 - 2 Reserved. 1 - 0 00b = This feature set is not supported.	0000h
128	F F	Security Status 15 - 9 Reserved. 8 - 0 000h = Security Mode Feature set is no supported.	0000h
129 - 159	X	Reserved	0000h
160	F	15- 0 0000h = the CFA Power Mode 1 is not supported.	0000h
161 - 162	F	Reserved.	0000h
163	F	Reserved.	0000h
164	F	Reserved.	001Bh
165 - 175	F	Reserved.	aaaa
176 - 205	F	Current media serial number is not indicated.	0000h
206 - 254	F	Reserved.	0000h
255	F	Integrity word 15- 8 Checksum 7 -0 Signature.	0000h

NOTES:

(1) F/V = Fixed/Variable content

F = the content of the word is fixed and does not change.

V = the content of the word is variable and may be changed depending on the state of the device, commands executed.

X = the content of the word may be fixed or variable.

C = vendor specific data which can be customized before device shipping.

(2) aaaa indicates an ASCII vendor string; x indicates a numeric nibble value.

(9) Idle – E3h

This command allows the host to place the device in the Idle mode and also set the Standby timer.

(10) Idle Immediate – E1h

This command allows the host to immediately place the device in the Idle mode.

(11) Initialize Device Parameters – 91h

This command enables the host to set the number of sectors per track and number of heads per cylinder.

(12) NOP – 00h

This controller will respond with command abort upon receipt of the NOP command.

(13) Read Buffer – E4h

This command enables the host to read the current contents of the device's sector buffer.

(14) Read DMA – C8h

This command allows the host to read data using the DMA data transfer protocol.

(15) Read Multiple – C4h

This command reads the number of sectors specified in the Sector Count register. The number of sectors per block is defined by the content of word 59 in the Identify Device response. A successful Set Multiple Mode command has to precede this command.

(16)Read Sector(s) – 20h

This command reads from 1 to 256 sectors as specified in the Sector Count register. A sector count of 0 will be treated as 256 sectors. The transfer begins at the sector specified in the LBA Low, LBA Mid, LBA High and Device registers.

(17)Read Verify Sector(s) – 40h

This command is identical to Read Sector(s) command, except that DRQ is never set and no data is transferred to the host.

(18)Seek – 70h

This command allows the host to provide advanced notification that particular data may be requested by the host in a subsequent command.

(19)Set Features – EFh

This command is used by the host to establish parameters that affect the execution of certain features. The following table defines all features that are supported by this controller. If any subcommand input value is not supported or is invalid, this controller will return command aborted.

Table 28: Set Feature Commands

Feature	Operation
01h	Reserved.
02h	Enable Write Cache.
03h	Set transfer mode based on value in Sector Count register.
05h	Enable Advanced Power Management.
09h	Reserved.
0Ah	Reserved.
44h	Reserved.
55h	Disable Read Look Ahead feature.
66h	Disable reverting to power-on defaults.
69h	Reserved.
81h	Reserved.
82h	Disable Write Cache.
85h	Disable Advanced Power Management.
89h	Reserved.
8Ah	Reserved.
96h	Reserved.
97h	Reserved.
9Ah	Reserved.
AAh	Enable Read Lock Ahead feature.
BBh	Reserved.
CCh	Enable reverting to power-on defaults.

(20)Set Multiple Mode – C6h

Upon receipt of this command, the controller will perform Read and Write Multiple operations and establishes the block count for these commands. This controller will set BSY to 1 and checks the Sector Register for the number of sectors per block.

(21)Sleep – E6h

Upon receipt of this command, the controller will set BSY and enter Sleep mode, clear BSY and generate an interrupt.

(22)Standby – E2h

This command will cause the device to enter Standby mode. The value in the Sector Count register is used to determine the time programmed into the Standby timer.

(23)Standby Immediate – E0h or 94h

This command will cause the device to immediately enter Standby mode.

(24)Write Buffer – E8h

This command allows the host to overwrite contents of a sector buffer with any data pattern desired.

(25)Write DMA – CAh

This command allows the host to write data using the DMA data transfer protocol.

(26)Write Multiple – C5h

This command is similar to the Write Sector(s) command. Interrupts are not presented on each sector but on the transfer of a block that contains the number of sectors defined by Set Multiple.

(27)Write Sector(s) – 30h

This command writes from 1 to 256 sectors as specified in the Sector Count register. A sector count of 0 will be treated as 256 sectors. This controller will interrupt for each DRQ block transferred.

6.3. ID Table Information**Table 29: Identify Data Information**

Word Address	Default value	Total Bytes	Data Field Type information
0	045Ah	2	General configuration
1	XXXXh	2	Default number of cylinders
2	0000h	2	Reserved
3	00XXh	2	Default number of heads
4	0000h	2	Obsolete
5	0240h	2	Obsolete
6	XXXXh	2	Default number of sectors per track
7-8	XXXXh	4	Number of sectors per card (Word 7 = MSW, Word 8 = LSW)
9	0000h	2	Obsolete
10-19	XXXXh	20	Serial number in ASCII (Right Justified)
20	0002h	2	Obsolete
21	0002h	2	Obsolete
22	0004h	2	Number of ECC bytes passed on Read/Write Long Commands
23-26	XXXXh	8	Firmware revision in ASCII. Big Endean Byte Order in Word
27-46	XXXXh	40	Model number in ASCII (Left Justified) Big Endean Byte Order in Word
47	8001h	2	Maximum number of sectors on Read/Write Multiple command
48	0000h	2	Reserved
49	0300h	2	Capabilities
50	0000h	2	Reserved
51	0200h	2	PIO data transfer cycle timing mode
52	0000h	2	Obsolete
53	0007h	2	Field validity
54	XXXXh	2	Current numbers of cylinders
55	XXXXh	2	Current numbers of heads

56	XXXXh	2	Current sectors per track
57-58	XXXXh	4	Current capacity in sectors (LBAs)(Word57=LSW , Word58=MSW)
59	0101h	2	Multiple sector setting
60-61	XXXXh	4	Total number of sectors addressable in LBA Mode
62	0000h	2	Reserved
63	0407h	2	Multiword DMA transfer. In PCMCIA mode this value shall be oh
64	0003h	2	Advanced PIO modes supported
65	0078h	2	Minimum Multiword DMA transfer cycle time per word.
66	0078h	2	Recommended Multiword DMA transfer cycle time.
67	0078h	2	Minimum PIO transfer cycle time without flow control
68	0078h	2	Minimum PIO transfer cycle time with IORDY flow control
69-79	0000h	20	Reserved
80	0010h	2	Major version number
81	0000h	2	Minor version number
82	7008h	2	Command sets supported 0
83	400Ch	2	Command sets supported 1
84	4002h	2	Command sets supported 2
85	0001h	2	Command sets Enable 0
86	0000h	2	Command sets Enable 1
87	0002h	2	Command sets Enable 2
88	001Fh	2	True IDE Ultra DMA Mode Supported and Selected (UDMA0~4)
89	0000h	2	Time required for Security erase unit completion
90	0000h	2	Time required for Enhanced security erase unit completion
91	0000h	2	Current Advanced power management level value
92-127	0000h	72	Reserved
128	0000h	2	Security status
129-159	0000h	64	vendor unique bytes
160	81F4h	2	Power requirement description
161	0000h	2	Reserved for assignment by the CFA
162	0000h	2	Key management schemes supported
163	0492h	2	CF Advanced True IDE Timing Mode Capability and Setting
164	001Bh	2	CF Advanced PCMCIA I/O and Memory Timing Mode Capability and set
165-175	0000h	22	80ns cycle in memory and IO mode
176-255	0000h	140	Reserved for assignment by the CFA

Notes:

Word 1: Default number of cylinders .

Word 3: Default number of heads .

Word 6: Default number of sectors per track .

Word 10~19: Serial number in ASCII .

Word 23~26: Firmware revision in ASCII.

Word 27~26: Model number in ASCII

Appendix A. Ordering Information

1. Part Number

◆ Standard Casing Industrial CF Cards – Hermit series

Capacity	0° C~ 70° C	-40° C~ 85° C
128MB	SPCFC128M-HACSC -UF	WPCFC128M-HAISI -UF
256MB	SPCFC256M-HACSC -UF	WPCFC256M-HAISI -UF
512MB	SPCFC512M-HACSC -UF	WPCFC512M-HAISI -UF
1GB	SPCFC001G-HACSC -UF	WPCFC001G-HAISI -UF
2GB	SPCFC002G-HACSC -UF	WPCFC002G-HAISI -UF
4GB	SPCFC004G-HACSC -UF	WPCFC004G-HAISI -UF
8GB	SPCFC008G-HACSC -UF	WPCFC008G-HAISI -UF
16GB	SPCFC016G-HACSC -UF	WPCFC016G-HAISI -UF

◆ Rugged Metal Casing Industrial CF Cards – Hermit series

Capacity	0° C~ 70° C	-40° C~ 85° C
128MB	SRCFC128M-HACSC -UF	WRCFC128M-HAISI -UF
256MB	SRCFC256M-HACSC -UF	WRCFC256M-HAISI -UF
512MB	SRCFC512M-HACSC -UF	WRCFC512M-HAISI -UF
1GB	SRCFC001G-HACSC -UF	WRCFC001G-HAISI -UF
2GB	SRCFC002G-HACSC -UF	WRCFC002G-HAISI -UF
4GB	SRCFC004G-HACSC -UF	WRCFC004G-HAISI -UF
8GB	SRCFC008G-HACSC -UF	WRCFC008G-HAISI -UF
16GB	SRCFC016G-HACSC -UF	WRCFC016G-HAISI -UF

Remarks:

1) The optional data-transfer modes and disk types are:

1. UR: optional as UDMA-4 mode / Removable disk type
2. **UF: defaulted as UDMA-4 mode / Fixed disk type**
3. PF: optional as PIO-4 mode / Fixed disk type
4. PR: optional as PIO-4 mode / Removable disk type
5. AR: optional as UDMA & PIO mode Auto-detection / Removable disk type
6. AP: optional as UDMA & PIO mode Auto-detection / Fixed disk type
7. PA: optional as PIO-4 mode / Fixed disk & Removable disk type Auto-detection
8. UA: optional as UDMA-4 mode / Fixed disk & Removable disk type Auto-detection
9. AA: optional as UDMA & PIO mode Auto-detection / Fixed disk & Removable disk type Auto-detection

2. Part Number Decoder

- Part number construction

X1 X2 X3 X4 X5 X6 X7 X8 X9—**X11 X12 X13 X14 X15**—**Z1 Z2** / **C**

- Decoder Description

X1 : Grade

S : Standard Grade – operating temperature 0° C ~ 70 ° C

W : Industrial Grade – operating temperature -40° C ~ 85 °C

X2 : The material of case

P : Plastic frame

R : Rugged metal frame

X3 X4 X5 : Product category

CFC : CompactFlash Card

X6 X7 X8 X9 : Capacity

016M: 16MB

032M: 32MB

064M: 64MB

128M: 128MB

256M: 256MB

512M: 512MB

001G: 1GB

002G: 2GB

004G: 4GB

008G: 8GB

016G: 16GB

X11 : Controller

H : Hyperstone (Hermit series)

X12 : Controller version

A, B, C.....

X13 : Controller Grade

C : Commercial grade

I : Industrial grade

X14 : Flash IC

S : Samsung Flash IC

X15 : Flash IC grade / Type

C : Commercial grade

I : Industrial grade

M : NAND gate MLC type Flash IC

Z1 Z2 : Data transfer rate /CF disk type

AA : PIO/UDMA & fixed/removable disk type auto-detected

AF : PIO/UDMA auto-detected; fixed disk type

AR : PIO/UDMA auto-detected; removable disk type

PA : PIO-4 mode; fixed/removable disk type auto-detected

PF : PIO-4 mode / fixed disk type

PR : PIO-4 mode / removable disk type

UA : UDMA-4 mode; fixed/removable disk type auto-detected

UF : Defaulted as UDMA-4 mode / fixed disk type

UR : UDMA-4 mode / removable disk type

C : Reserved for specific requirement

C : Conformal-coating

Appendix B. Limited Warranty

APRO warrants your Industrial CompactFlash (CF) Card against defects in material and workmanship for the life of the drive. The warranty is void in the case of misuse, accident, alteration, improper installation, misapplication or the result of unauthorized service or repair. The implied warranties of merchantability and fitness for a particular purpose, and all other warranties, expressed or implied, except as set forth in this warranty, shall not apply to the products delivered. In no event shall APRO be liable for any lost profits, lost savings or other incidental or consequential damages arising out of the use of, or inability to use, this product.

BEFORE RETURNING PRODUCT, A RETURN MATERIAL AUTHORIZATION (RMA) MUST BE OBTAINED FROM APRO.

Product shall be returned to APRO with shipping prepaid. If the product fails to conform based on customers' purchasing orders, APRO will reimburse customers for the transportation charges incurred.

Appendix C. After Service

1. Policy

In order to return any item for repair, an RMA (Return Merchandise Authorization) number must be assigned by APRO. Customers need to provide the following information, before an RMA will be issued:

- **Product model**
- **Quantity**
- **Lot number**
- **Defect description**
- **Customer name**
- **Contact person**
- **Email address or telephone number**
- **Shipping address**

In order to receive an RMA number, please contact our customer service department via fax or email:

- **Fax the RMA Request Form to 886-2-2929 0307. The RMA Request Form can be downloaded from <http://www.apro-tw.com/support/rmaform.htm>)**
- **Email to rma@apro-tw.com.tw**

The description of the defect needs to be clear and complete in order for APRO to address the problem according to customer expectations. Without a clear description, APRO can only provide a basic test of the returned products.

1.1. Warranty period

- **SPFCxxxx-HACSC- Series & SRCFCxxxx-HACSC-Series 3 year**
- **WPCFCxxxx-HAISI- Series & WRCFCxxxx-HAISI-Series 5 year**

1.2. Service charge under warranty period

For a warranty repair, there is no charge.

Remark:

The warranty does not cover product damage due to improper operation or force of nature such as fire or flood.

1.3. Service charge for out of warranty period

Out of warranty repair charges are dependent on component cost and labor time. APRO will issue an estimate after diagnosing the problem.

1.4. End of Life service

APRO cannot guarantee repair of any products beyond one year of End-of-Life due to limited availability of replacement components. If repair components are not available, APRO will suggest equivalent products for purchase and offer special pricing.

1.5. Shipping Charges

The customer is responsible for packaging the product such that no additional damage occurs during normal shipping and handling. Any freight-collect shipments without notice in advance will be refused.

For warranty repairs, the customer is responsible for the cost of shipping the product back to APRO. APRO will pay for shipping back to the customer.

For DOA warranty replacements, APRO will pay shipping charges for return and replacement. APRO reserves the right to use the most economical shipping method available.

2. Procedure

The definition of defective products fall into three categories as described below:

- DOA (Defect on Arrival): Defect occurs within 30 days of purchase.
- RMA in warranty period
- RMA out of the warranty period

The above terms are determined by the purchase date on the invoice up to the time to product is returned to APRO. APRO's repair service procedure is as follows:

2.1. Request an RMA Number from APRO:

- (1) Fill out an "RMA Request Form" and send it by fax to +886-2-2929 0307 or e-mail to rma@APRO-tw.com
- (2) APRO's RMA engineer will check that the "RMA Request Form" has been completed with precise information. Then the customer will receive a RMA number.
If you need a replacement rather than wait for the returned defective product to be repaired, this requirement must be noted in your "RMA Request Form".

2.2. Package and Delivery to APRO

- (1) Returned products have to be packed properly to avoid damage during the transportation.
- (2) DOA products: DOA products qualify for complete replacement and have to be returned with all accessories included in the original purchase.

-
- (3) Please indicate your unique RMA number on the top outside of the package.
 - (4) To speed up the RMA/DOA procedure, please notify us by e-mail (rma@APRO-tw.com) with information that includes the shipping date, the name of carrier and the tracking number of the package.

2.3. Product Check On Arrival

- (1) APRO's RMA engineer will check your product within 8 hours since arrival.
- (2) If the product arrives undamaged and conforms to the conditions described on the "RMA Request Form", it will be for repairing.
- (3) If the product is damaged or there is some inconsistency with the "RMA Request Form" description, APRO will contact and confirm the status with the customer before proceeding.

2.4. Repair

- (1) The RMA engineer will repair the defect as described by the customer. The products will also be tested to ensure it is in proper working order.
- (2) If no additional problems are detected, APRO will notify the customer.
- (3) If the customer does not reply us within 48 hours, and no failure occurs during testing, the product will be processed as NTF. (No testing failure).

2.5. Charge

The customer will be charged for repairs under below conditions:

- RMA is out of the warranty period
- RMA or DOA terms apply, but it is determined by APRO's RMA engineer that the defect was caused by abuse, misuse or unauthorized repair.

2.6. Package and Delivery to the customer

- (1) We will properly pack the repaired product along with a RMA report.
- (2) The RMA number and quantity will be clearly marked on the package.
- (3) The customer will receive an e-mail notification of the product RMA number and shipping advice.